

F800A

Klein duimpje
Le petit poucet
Daümelinchen
Tom thump
Pulgarcito
Pollicino

Montagehandleiding Notice de montage Assembling manual Montageanleitung Instrucciones para el montaje Istruzioni di installazione

Leeftijd
Age group
Age / Alter
Edad / Età
2 - 6

EUROPLAY nv
Eegene 9
B-9200 DENDERMONDE
tel. 32.52.22 66 22
fax.32.52.22 67 22
www.europlay.eu

Dat.: 19/12/2016
Rev.: -
Page: 1/7

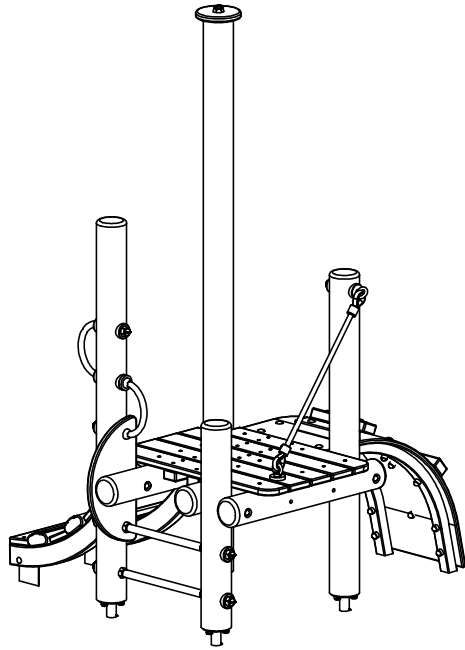

73,09kg

VALHOOGTE / HAUTEUR DE CHUTE /
FALL HEIGHT / FALLHÖHE/
ALTURA DE CAÍDA / ALTEZZA DI CADUTA

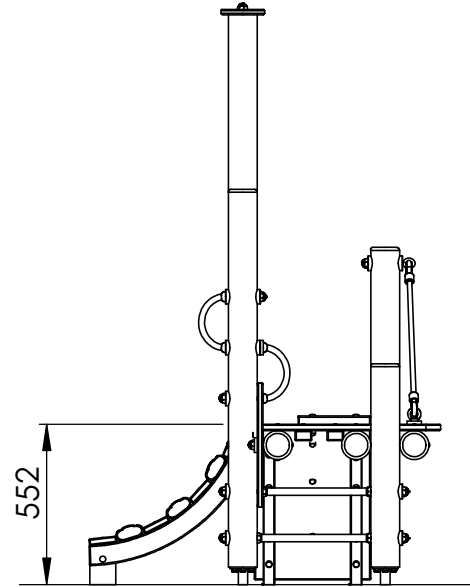

VEILIGHEIDSAFSTAND / ESPACE DE CHUTE / SAFETY AREA /
SICHERHEITSAFSTAND / ZONA DE SEGURIDAD / DISTANZA DI SICUREZZA

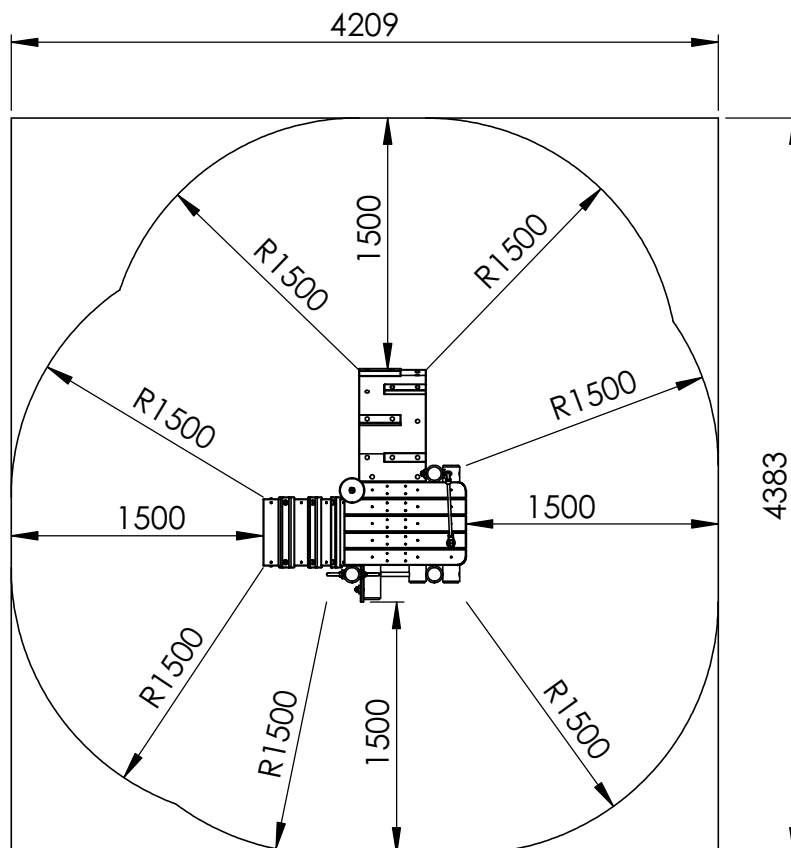

AFMETINGEN
DIMENSIONS
MASSE
DIMENSIONES
DIMENSIONI
L: 1,4m
Br: 1,4m
H: 2,0m











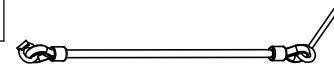

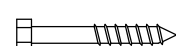
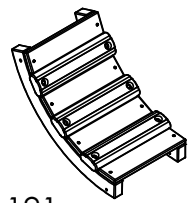
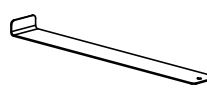
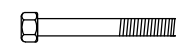
18,5m²

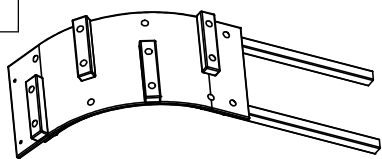
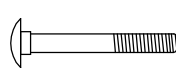
F800A

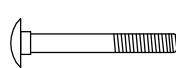
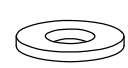
Montagehandleiding - Notice de montage
 Assembling manual - Instrucciones para el montaje
 Montageanleitung - Istruzioni di installazione

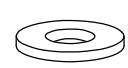
Dat.: 19/12/2016

Page: 2/7

 <p>F800A BASIC</p>	1x F300-As-Touw-01 	2x M8 2x M10 
	Ø16x627 0,5kg	2x M10x80 
1x F300-As-Klimboog-01 	2x 685x3 	1x M10x125 
724x420x191 6kg	685x60x40 1kg	1x 
1x F300-As-Bolboog-01 	2x M8x55 	2x 
	1311x400x388 16,6kg	2x M10x105 
	2x M8 	2x 
	5x M10 	1x 
	2x M8 	1x 
	3x M10 	

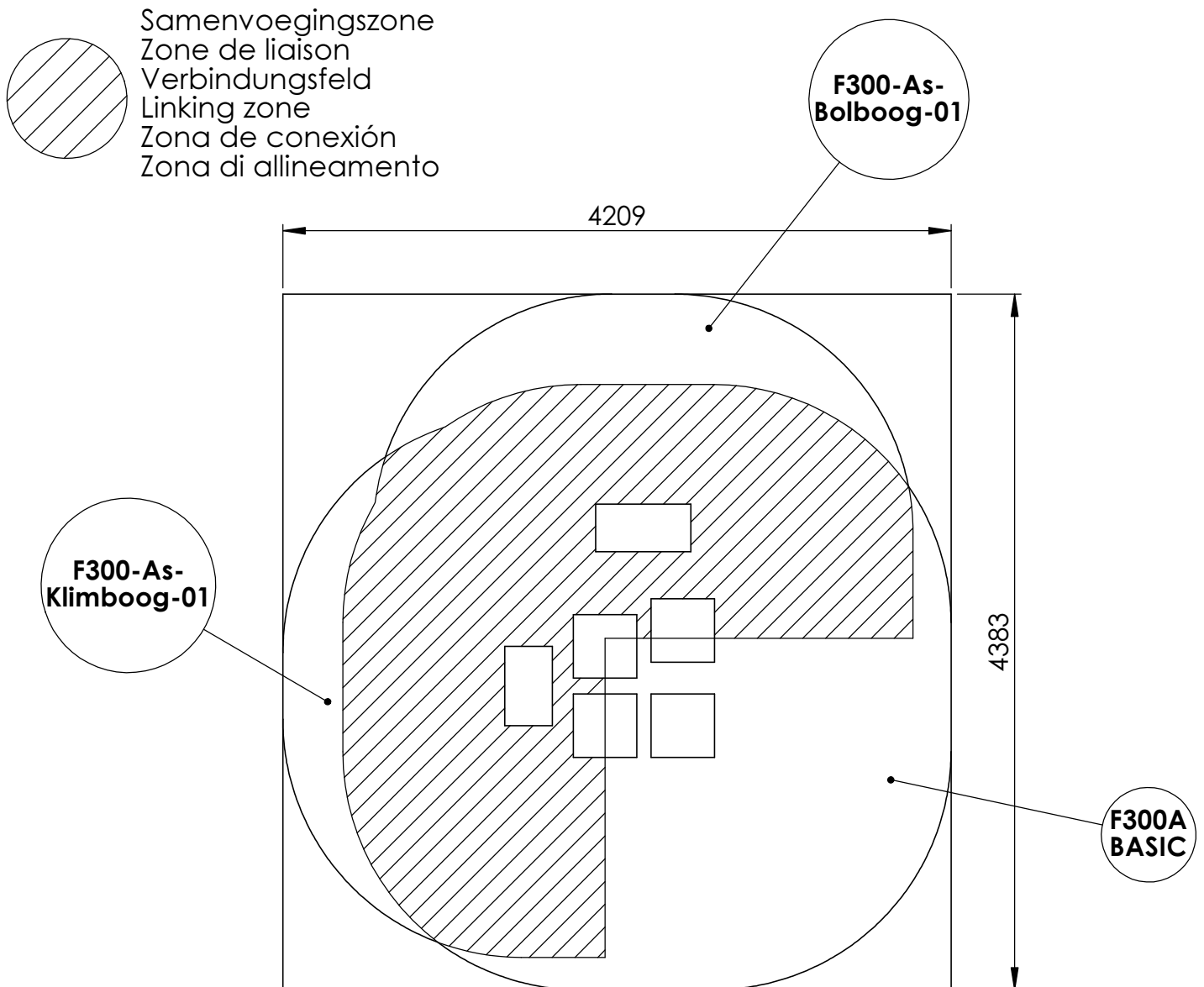

01

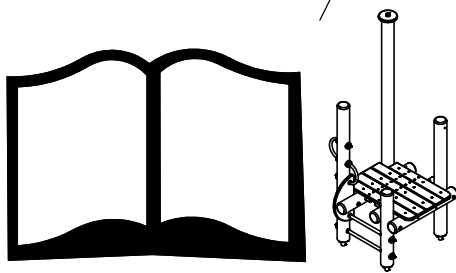
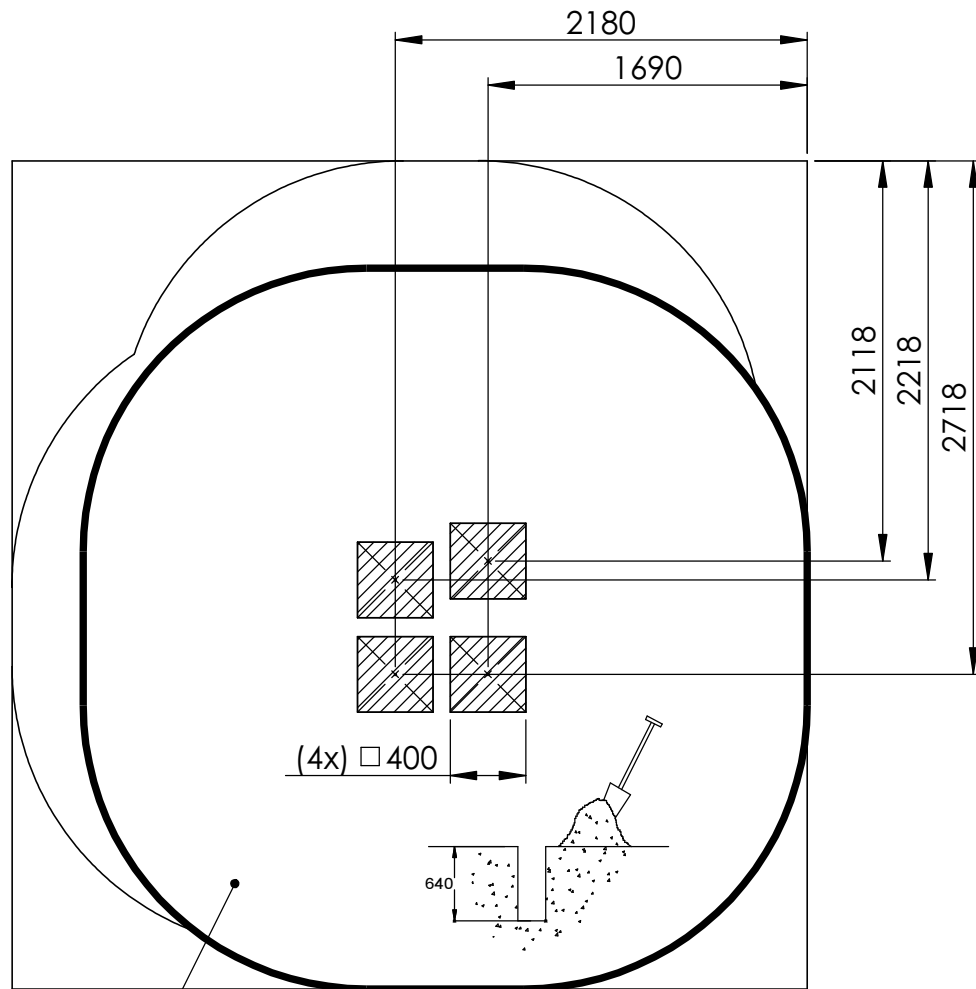

F800A
BASIC

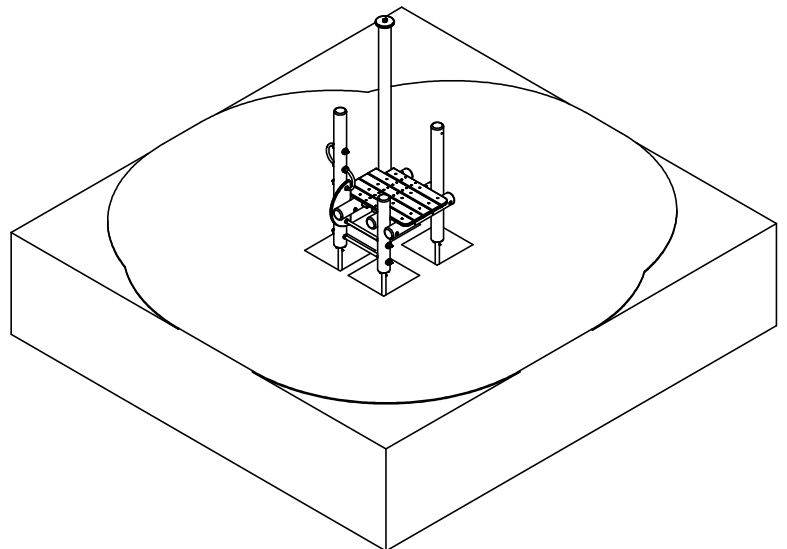

02

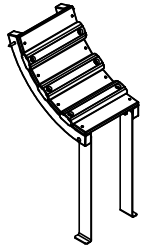

F300-As-Klimboog-01

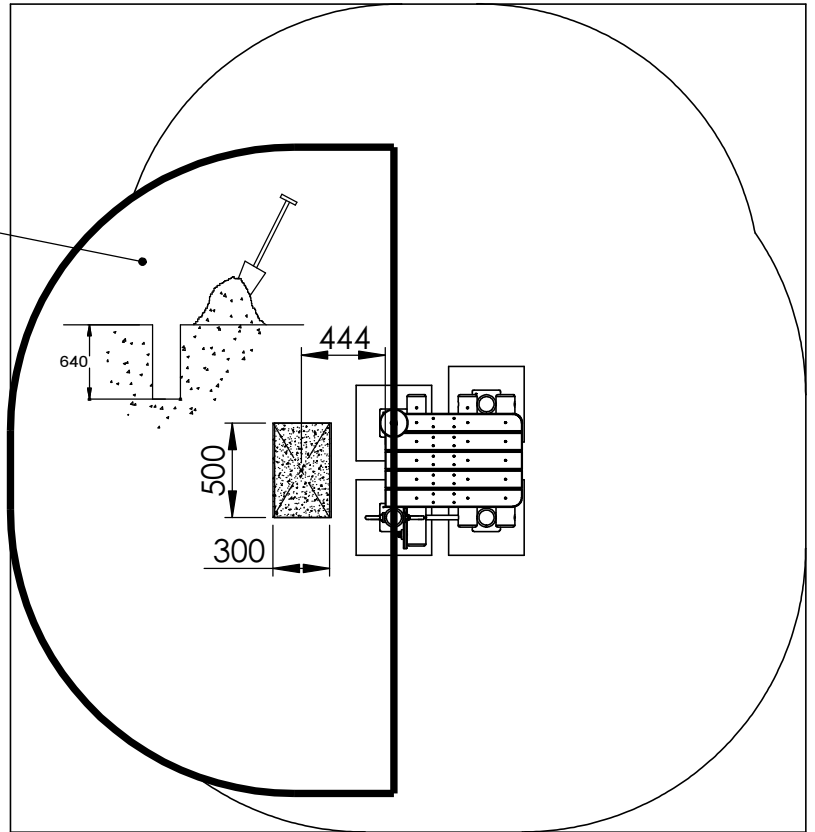

F300-As-Klimboog-01

1x

685x3
2x

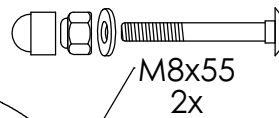

M8x55
2x

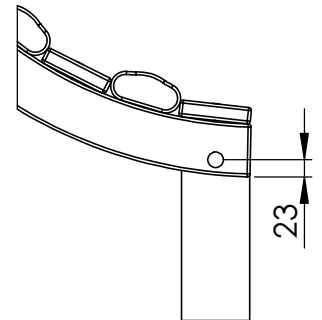
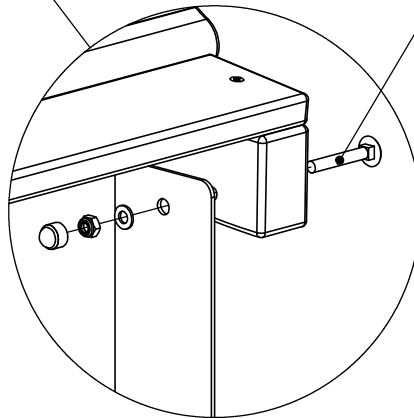

23

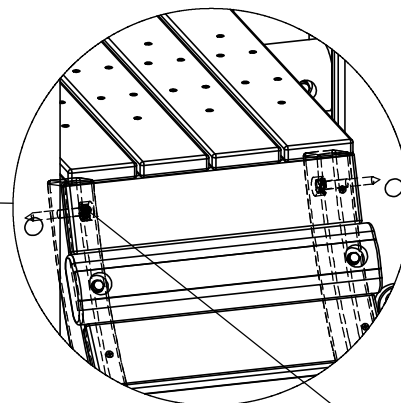

M10x80
2x

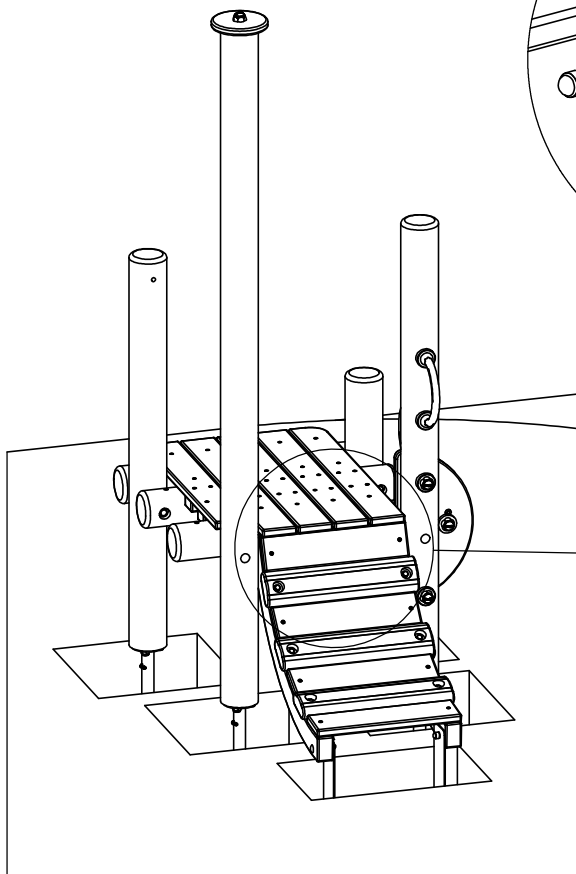
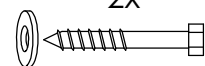

03

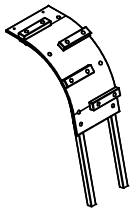

F300-As-
Bolboog-01

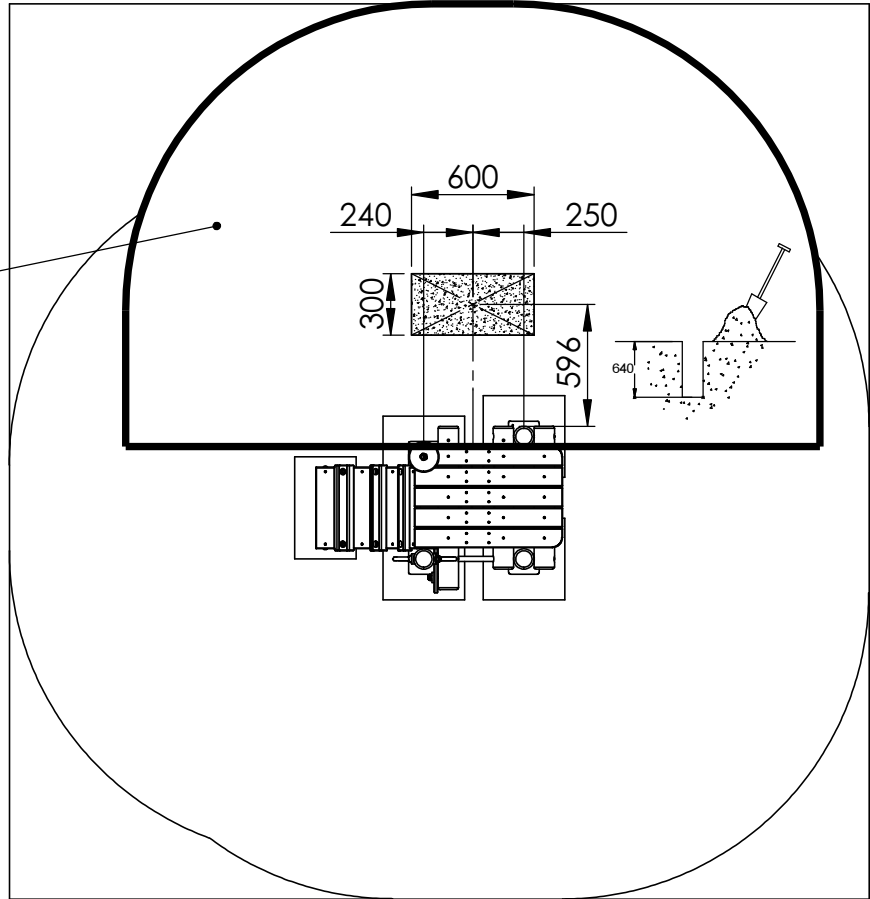

F300-As-Bolboog-01
1x

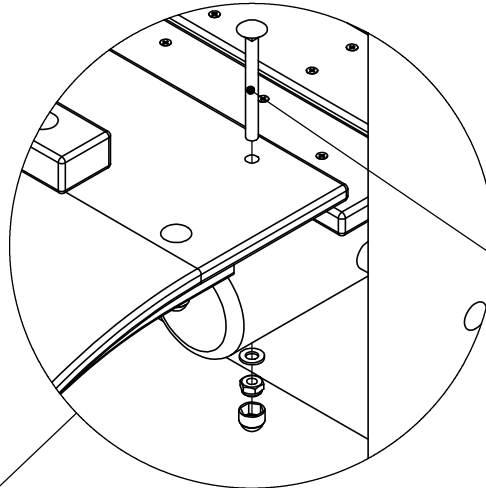

M10x105
2x

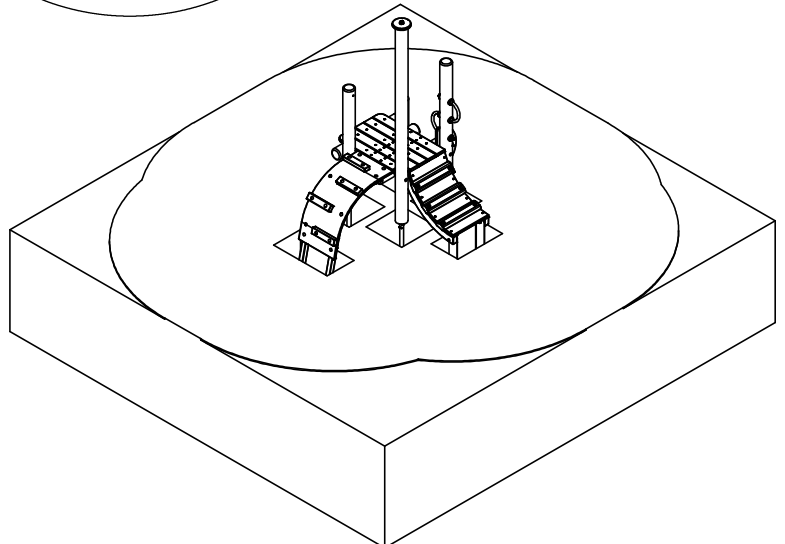
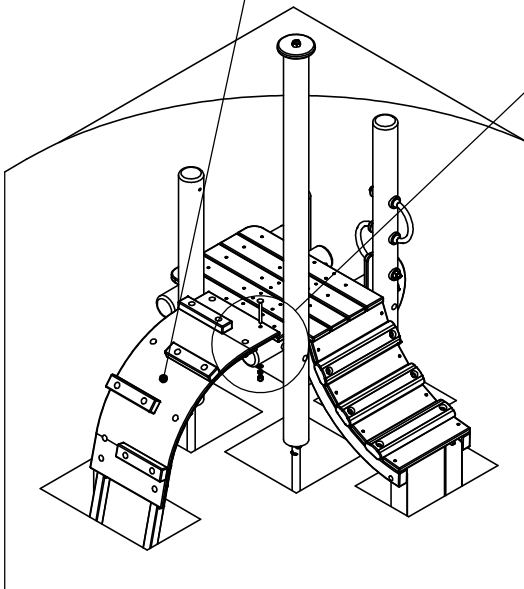

07

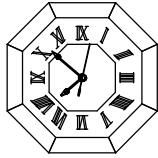
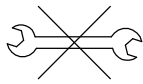
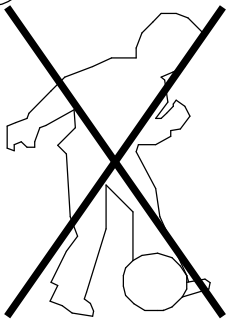
**72h**

08

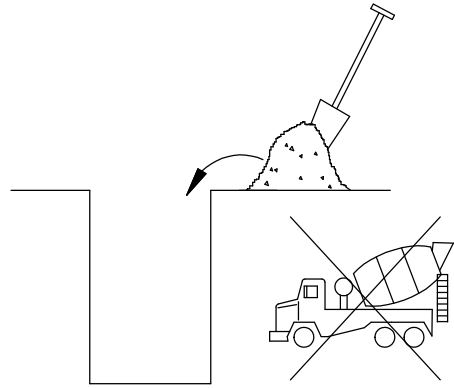

09

Bij droog weer moeten alle bouten en schroeven opnieuw aangespannen worden.
Par temps sec il faut resserrer régulièrement toute la visserie.

By dry and warm weather check the tightness of all bolts and screws.

Bei trockenem Wetter müssen alle Schrauben und Bolzen aufs neue angespannt werden.

Para el tiempo seco, se necesita cerrar o ajustar los tornillos y tuercas.

Con tempo asciutto, tutti i bulloni e le viti devono essere avvitati nuovamente.

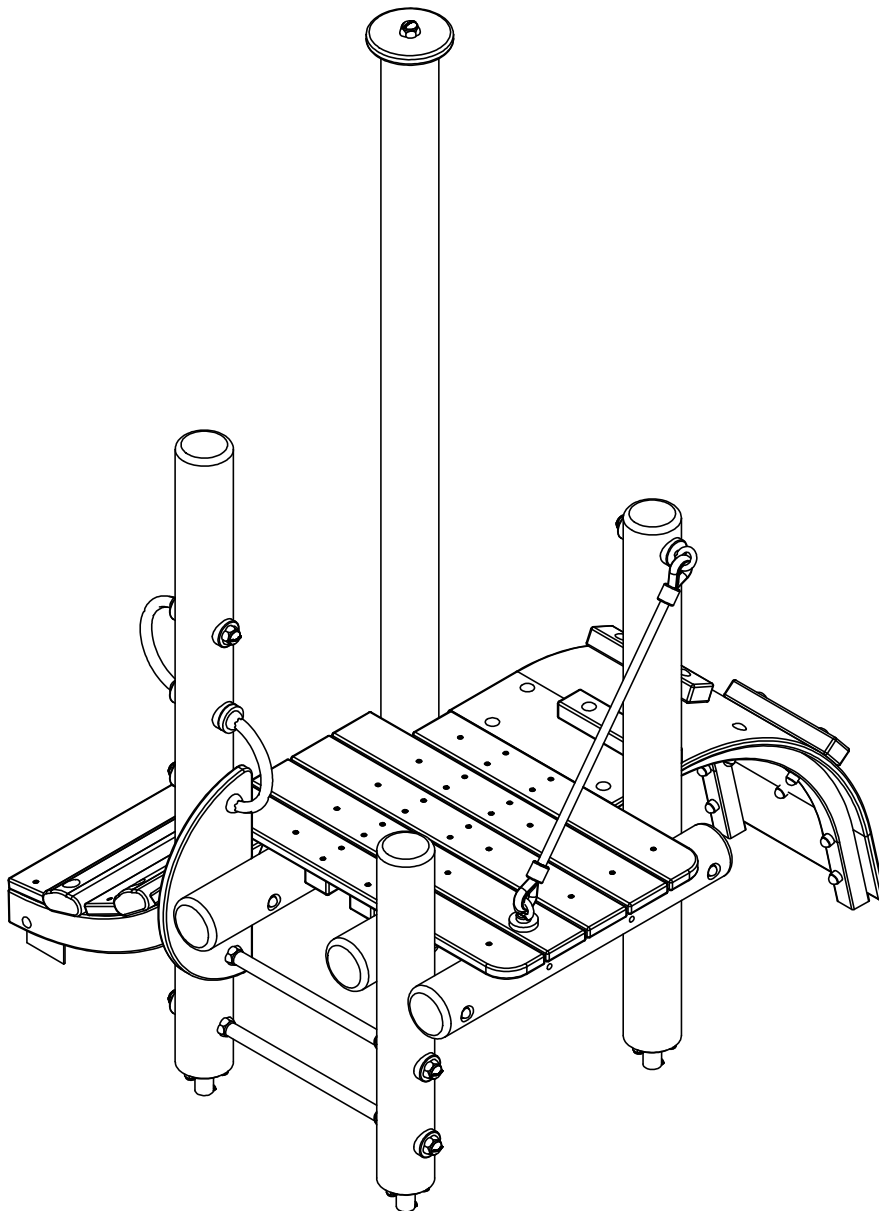

F800B

Klein duimpje
Le petit poucet
Daümelinchen
Tom thump
Pulgarcito
Pollicino

Montagehandleiding Notice de montage Assembling manual Montageanleitung Instrucciones para el montaje Istruzioni di installazione

Leeftijd
Age group
Age / Alter
Edad / Età
2 - 6

EUROPLAY nv
Eegene 9
B-9200 DENDERMONDE
tel. 32.52.22 66 22
fax.32.52.22 67 22
www.europlay.eu

Dat.: 19/12/2016
Rev.: -
Page: 1/7

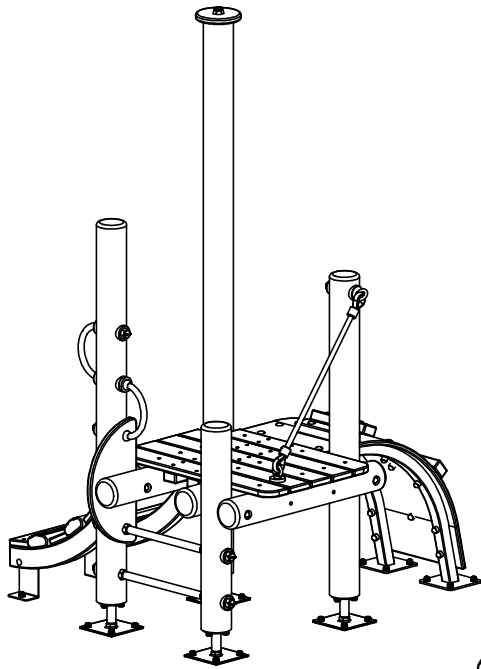

66,88kg

VALHOOGTE / HAUTEUR DE CHUTE /
FALL HEIGHT / FALLHÖHE/
ALTURA DE CAÍDA / ALTEZZA DI CADUTA

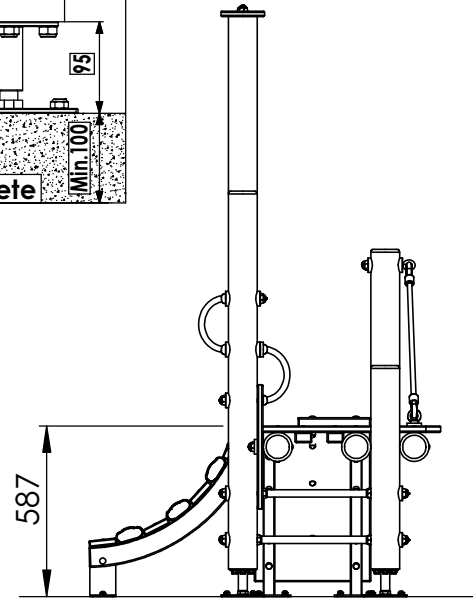
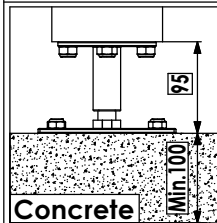

VEILIGHEIDSAFSTAND / ESPACE DE CHUTE / SAFETY AREA /
SICHERHEITSAFSTAND / ZONA DE SEGURIDAD / DISTANZA DI SICUREZZA

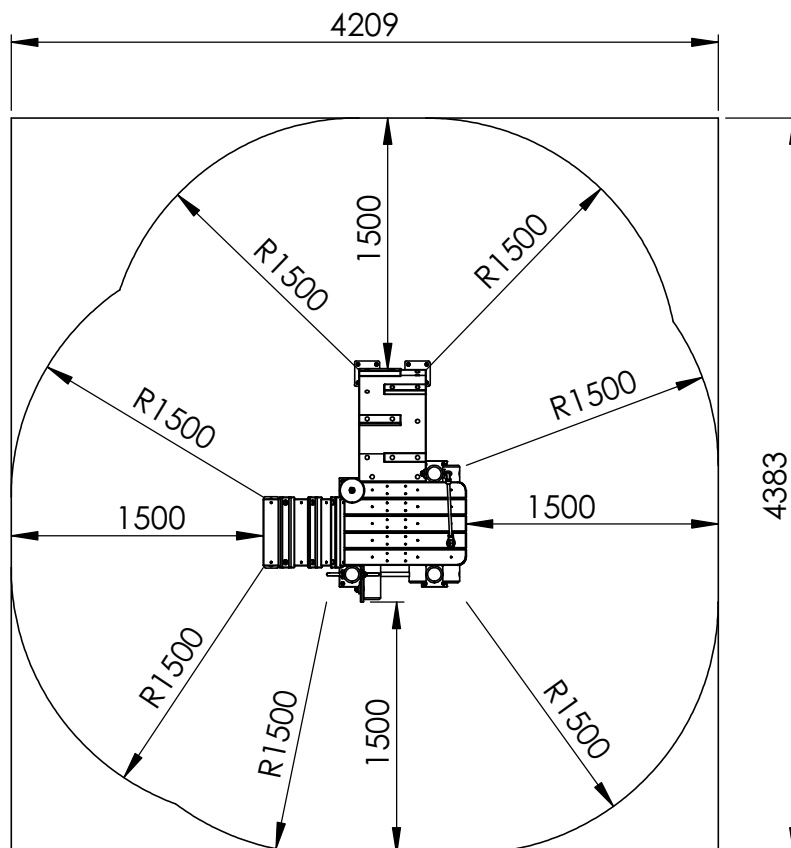

AFMETINGEN
DIMENSIONS
MASSE
DIMENSIONES
DIMENSIONI
L: 1,4m
Br: 1,4m
H: 2,0m

18,5m²

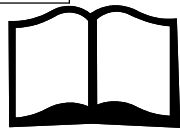

F800B
BASIC

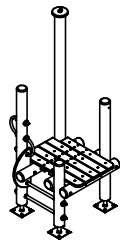

1x F300-As-Touw-01		2x M8	
$\varnothing 16 \times 627$	0,5kg	2x M10	

2x F300-M-Voetijzer-01		2x M10x80	
148x88x60	0,42kg	1x M10x125	

2x M8x55		1x	
2x M10x105		2x	

2x M8		2x	
5x M10		1x	

2x M8		1x	
3x M10			

26x M10x95			
------------	--	--	--

1x F300-As-Klimboog-01		6kg
724x420x191		

1x F300-As-Bolboog-02		16,6kg
1311x400x388		

Samenvoegingszone
 Zone de liaison
 Verbindungsfeld
 Linking zone
 Zona de conexión
 Zona di allineamento

F300-As-Klimboog-02

F300-As-Bolboog-02

F300B BASIC

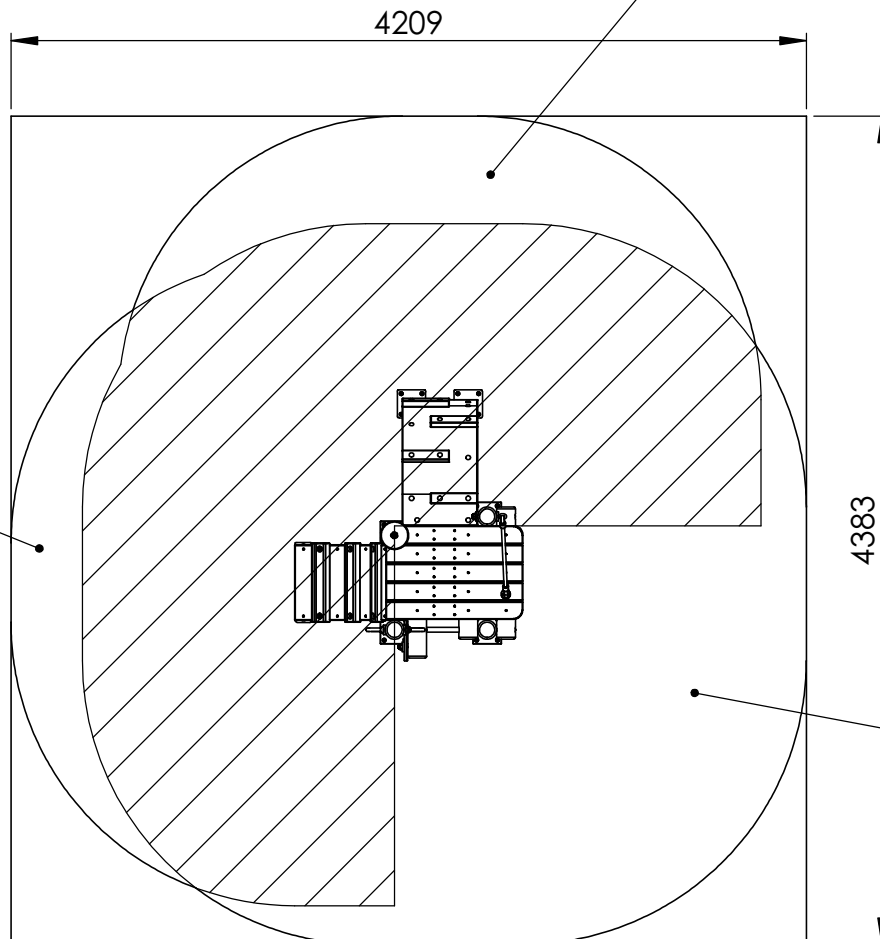

01

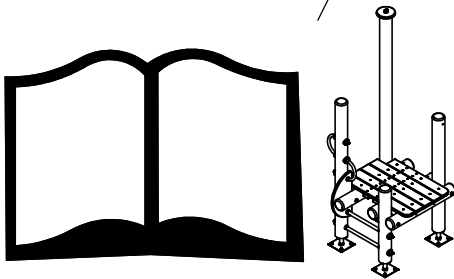
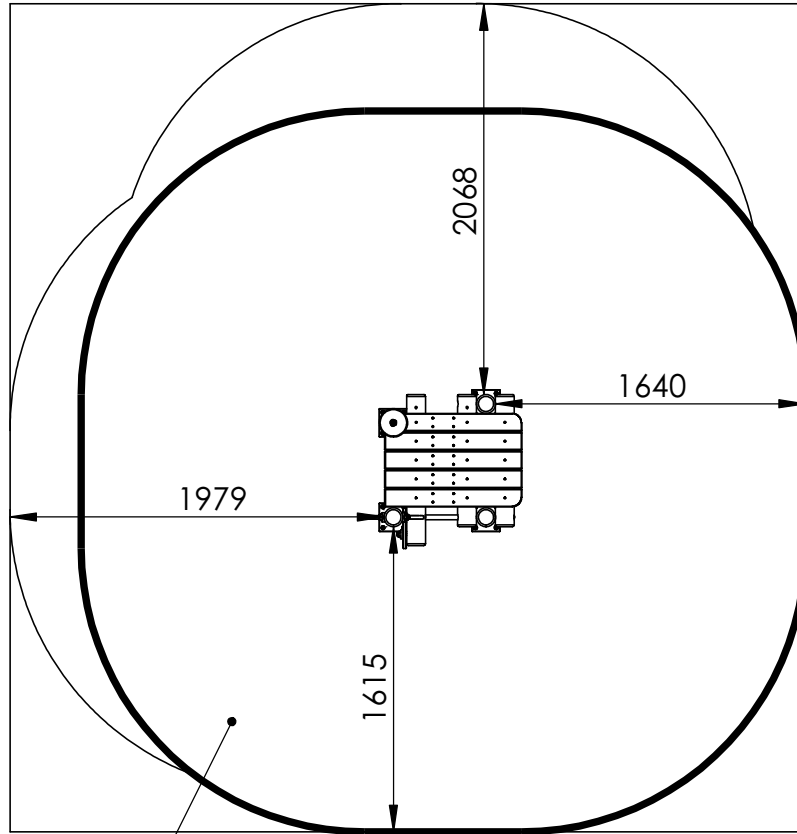

F800B
BASIC

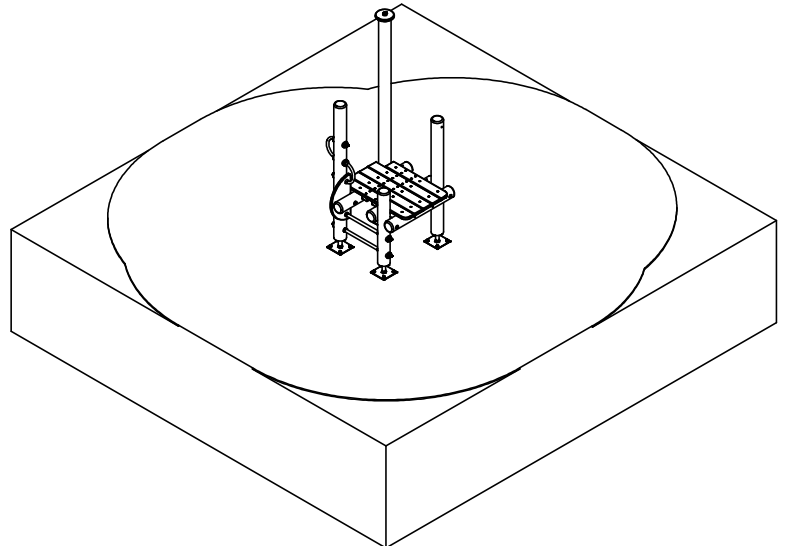

02

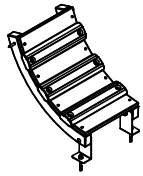

F300-As-Klimboog-02

F300-As-Klimboog-01

1x

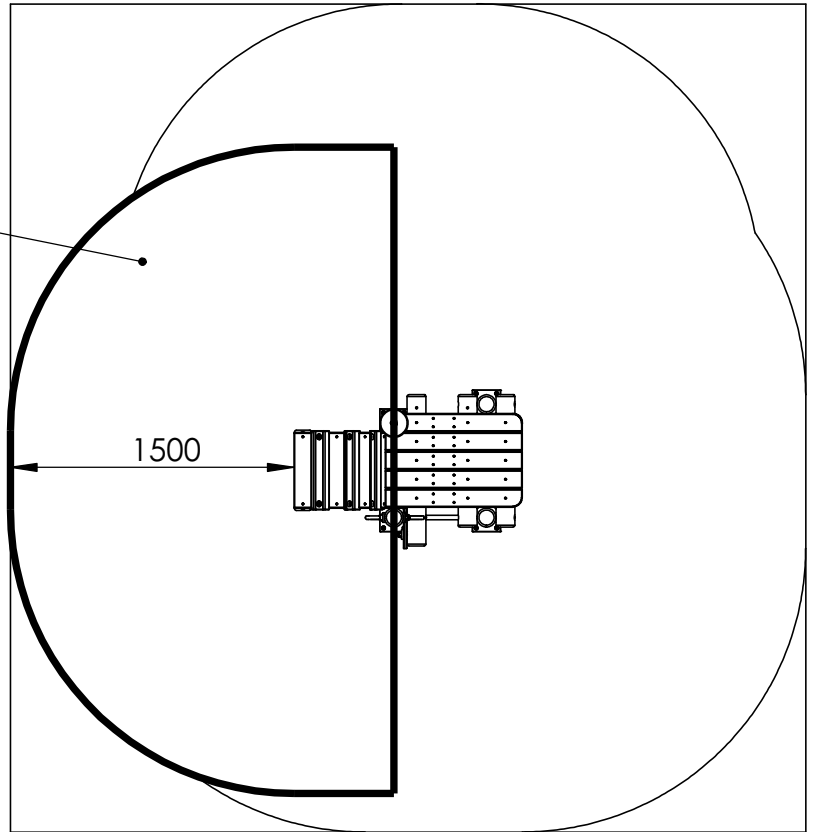
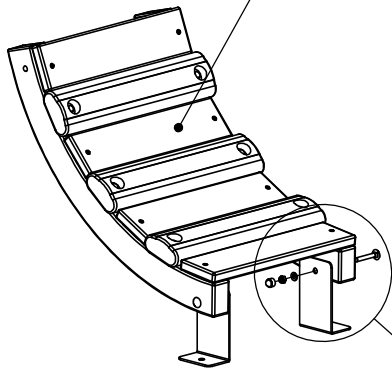

1500

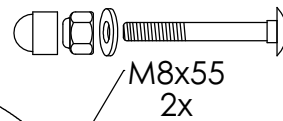

M8x55
2x

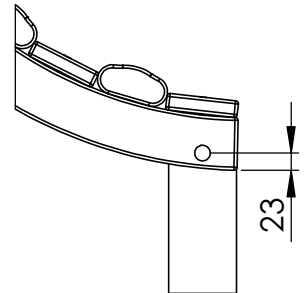
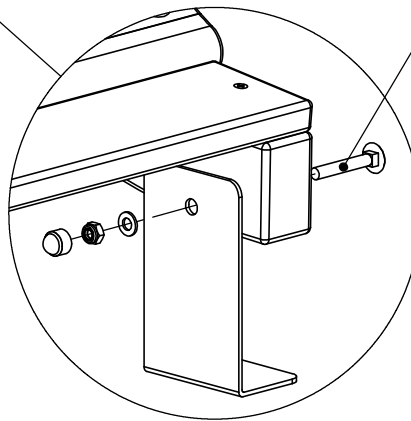

23

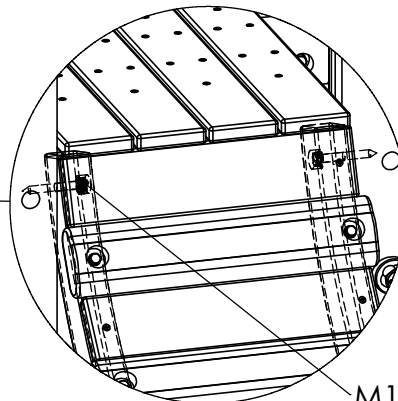
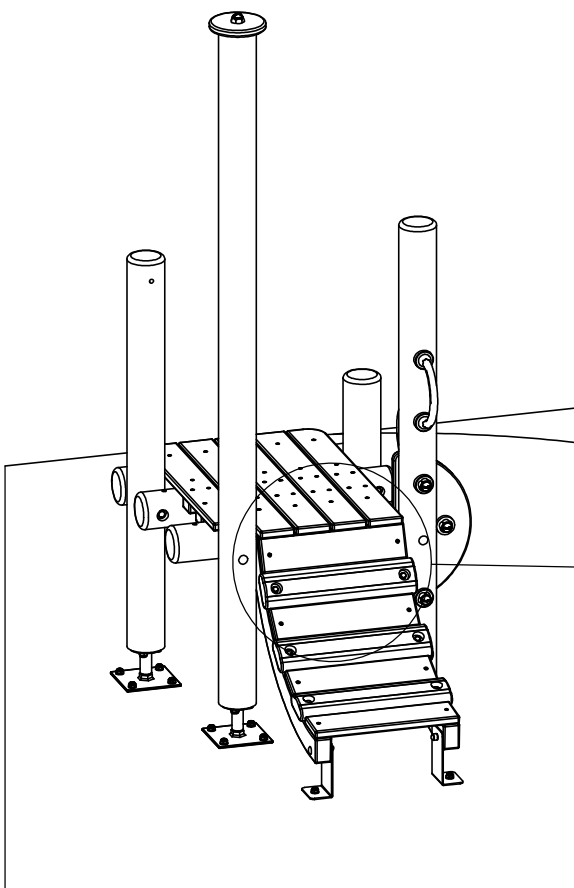

M10x80
2x

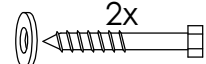

03

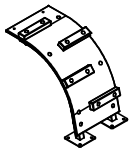

F300-As-
Bolboog-02

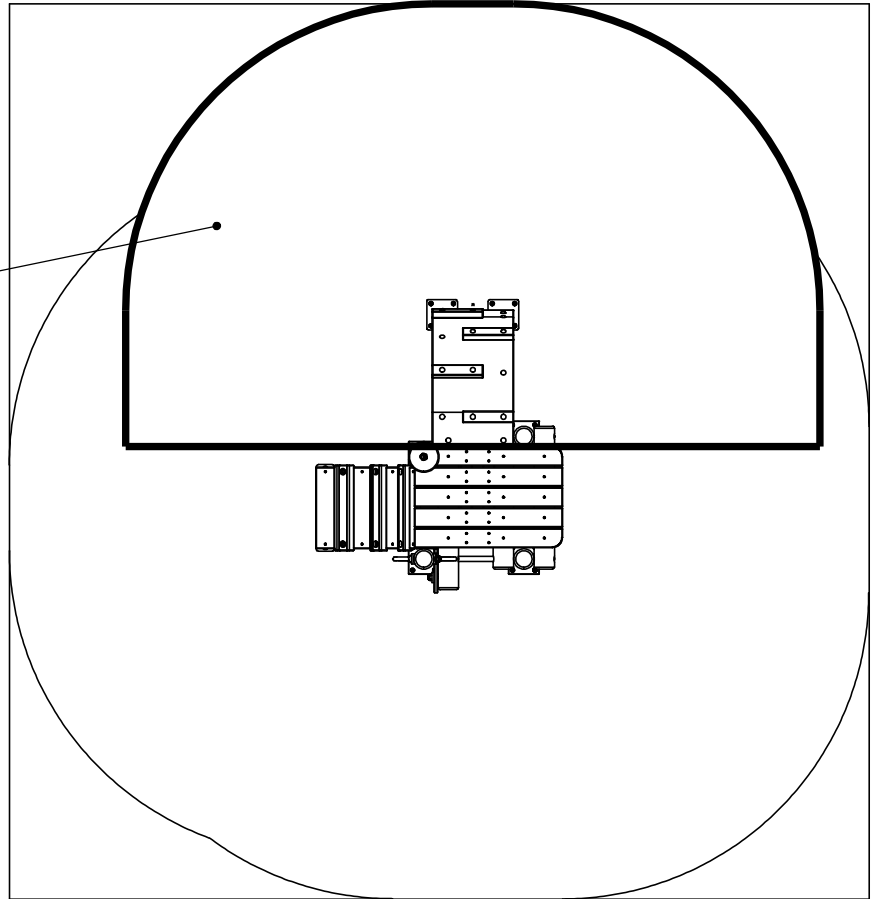

F300-As-Bolboog-02
1x

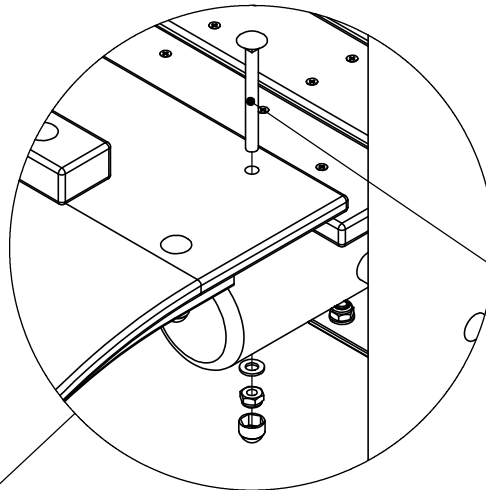

M10x105
2x

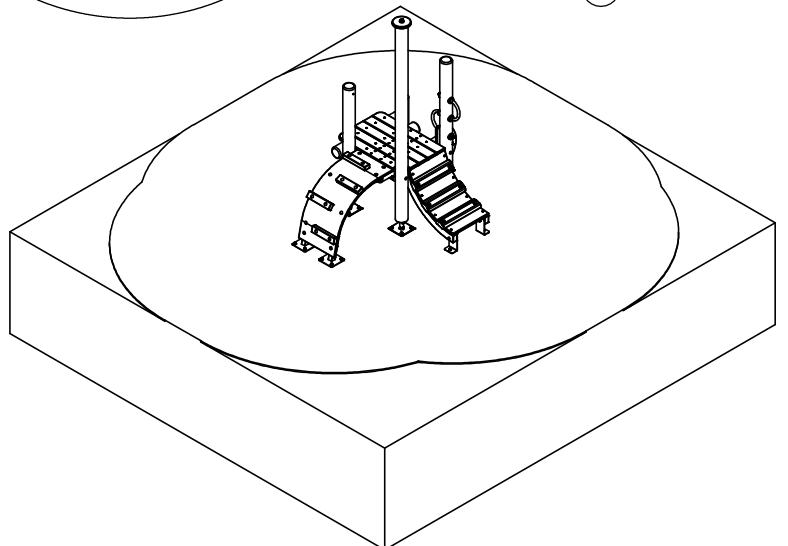
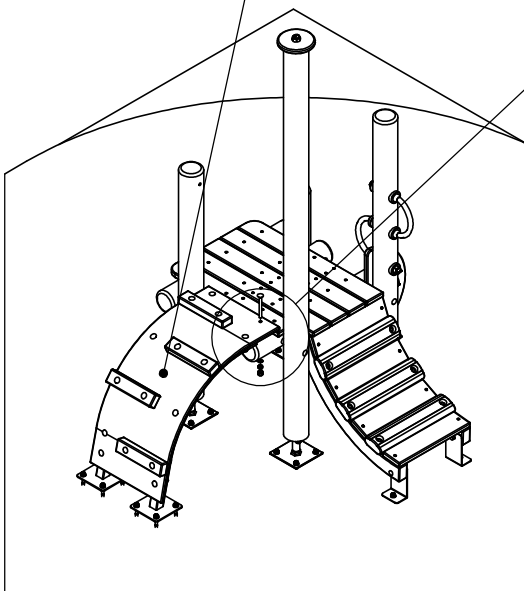

04

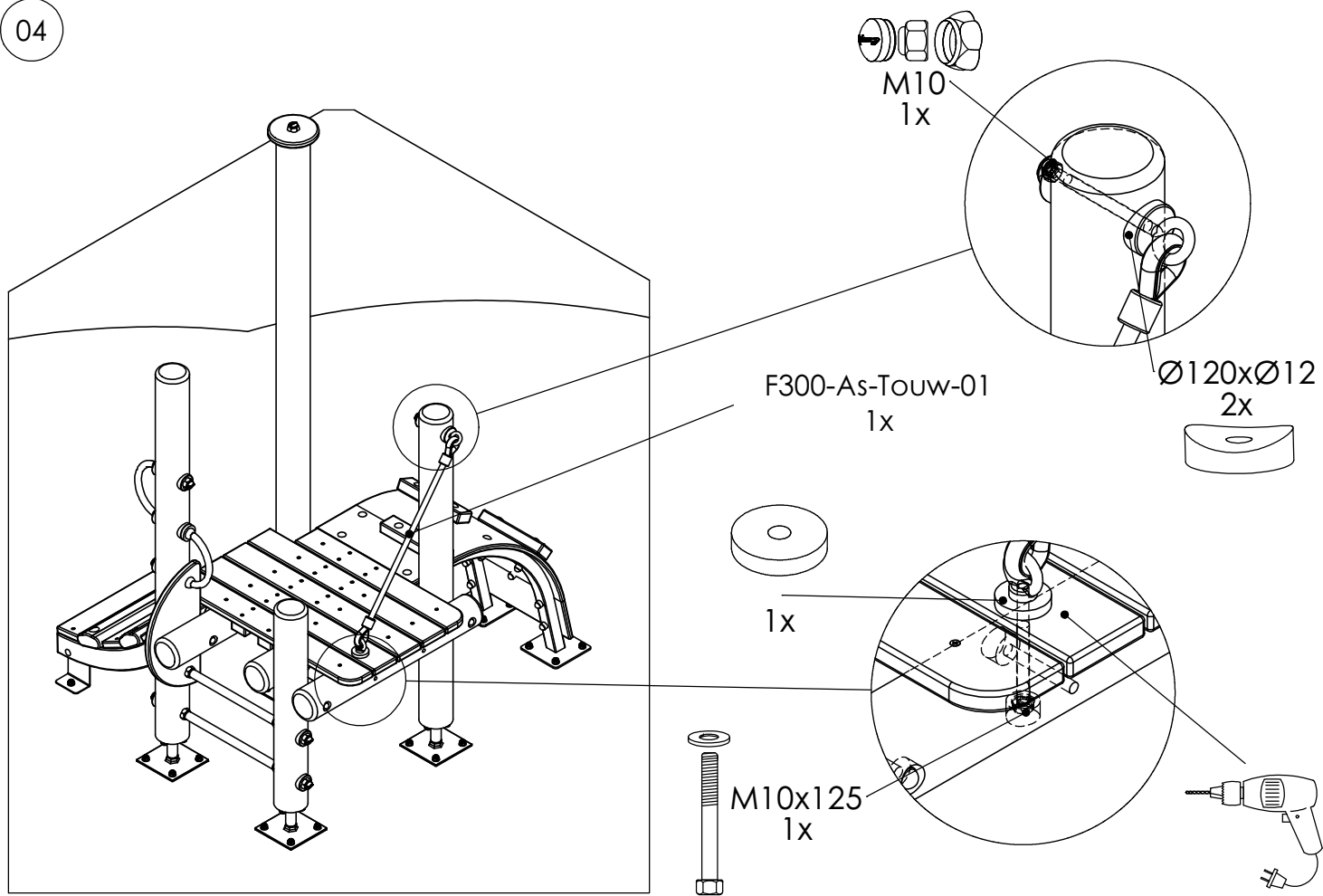

05

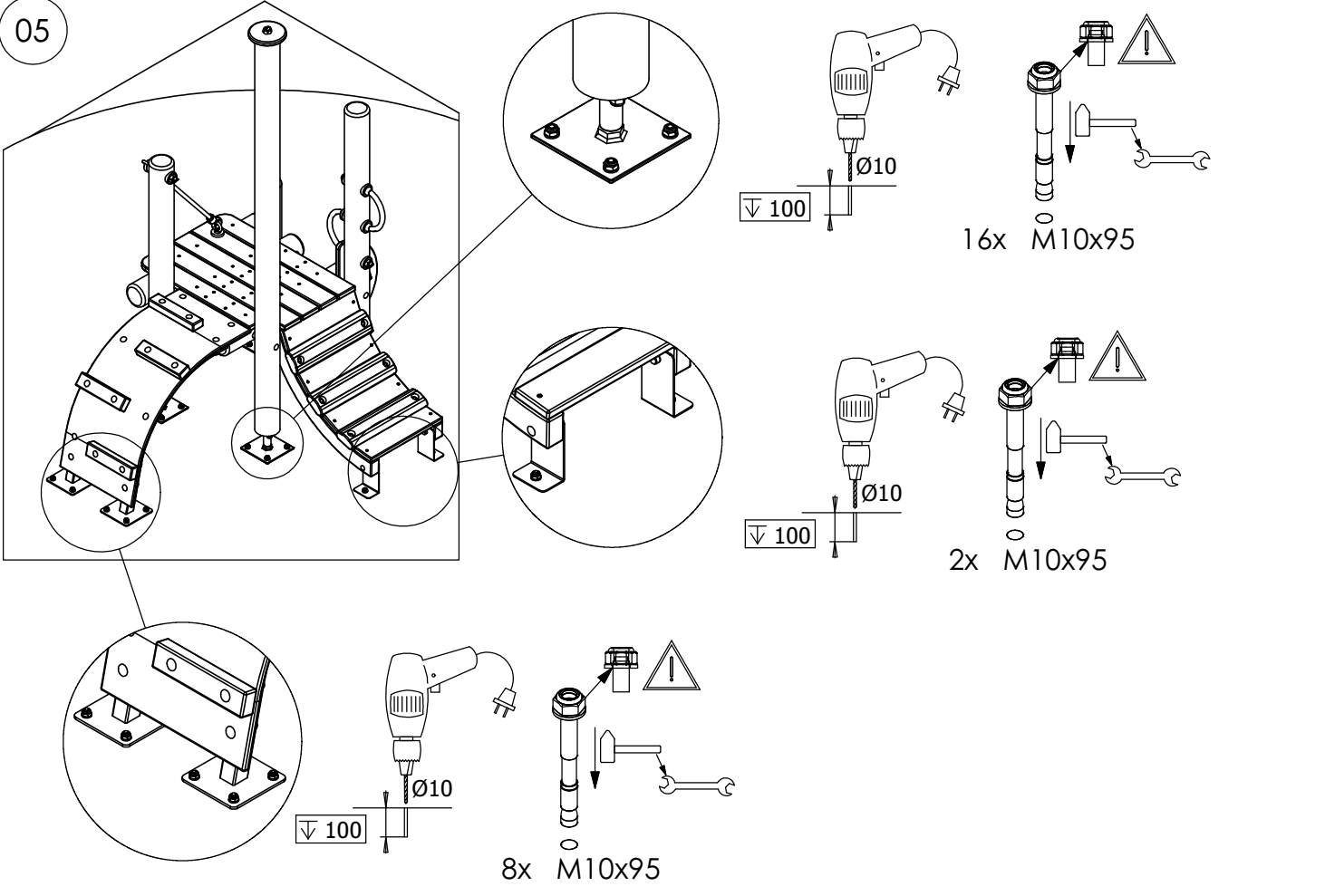

06

Bij droog weer moeten alle bouten en schroeven opnieuw aangespannen worden.
Par temps sec il faut resserrer régulièrement toute la visserie.
By dry and warm weather check the tightness of all bolts and screws.
Bei trockenem Wetter müssen alle Schrauben und Bolzen aufs neue angespannt werden.
Para el tiempo seco, se necesita cerrar o ajustar los tornillos y tuercas.
Con tempo asciutto, tutti i bulloni e le viti devono essere avvitati nuovamente.

