

RO500

KEVERBRUGJE
PONT DE COCCINELLE
BEETLE BRIDGE
KÄFER-BRÜCKE
PUENTE DE ESCARABAJO
PONTICELLO DEL
MAGGIOLINO

Montagehandleiding

Notice de montage

Assembling manual

Montageanleitung

Instrucciones para el montaje

Istruzioni di installazione

Leeftijd:
Age: 6-14
Age group:
Alter:
Edad:
Età:

EUROPLAY nv
Eegene 9
B-9200 DENDERMONDE
tel. 32.52.22 66 22
fax.32.52.22 67 22
www.europlay.eu

Dat.: 19/08/2015

Page: 1/10

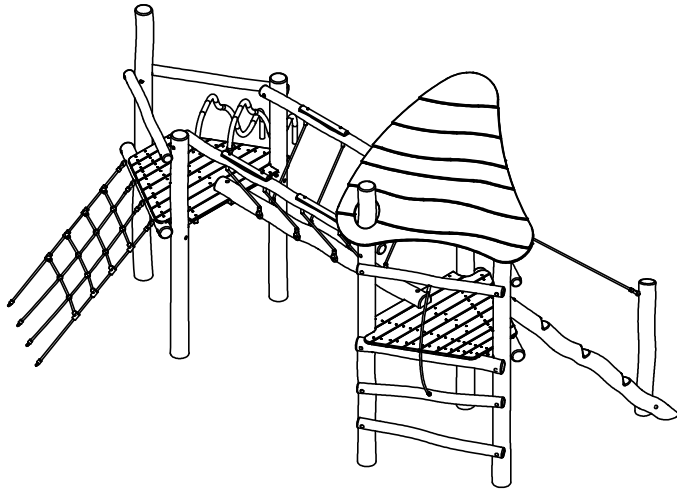

VALHOOGTE / HAUTEUR DE CHUTE /
FALL HEIGHT / FALLHÖHE/
ALTURA DE CAÍDA / ALTEZZA DI CADUTA

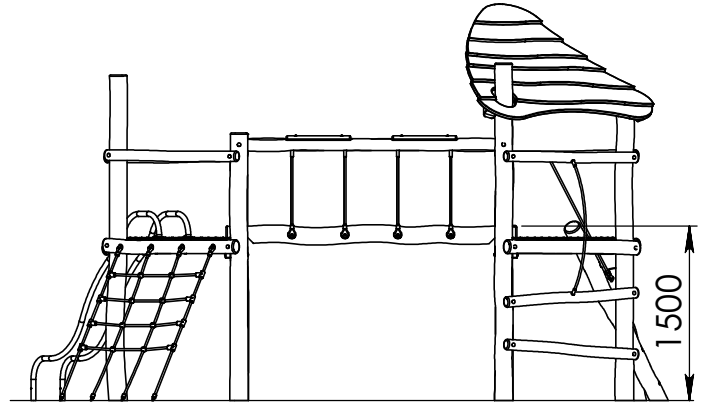

VEILIGHEIDSAFSTAND / ESPACE DE CHUTE / SAFETY AREA /
SICHERHEITSAFSTAND / ZONA DE SEGURIDAD / DISTANZA DI SICUREZZA

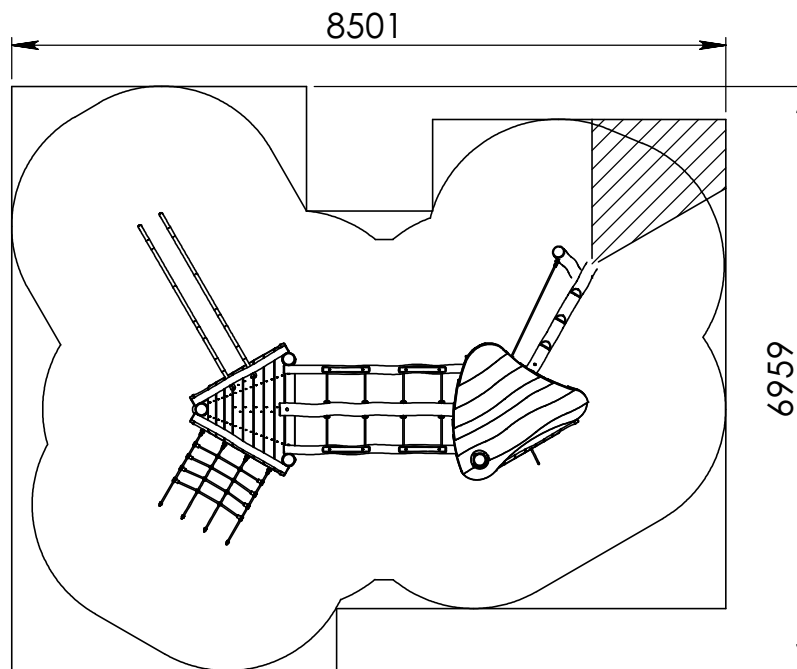

AFMETINGEN
DIMENSIONS
MASSE
DIMENSIONES
DIMENSIONI
L : 5,6m
H: 3,4m
Br: 4,0m

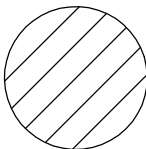







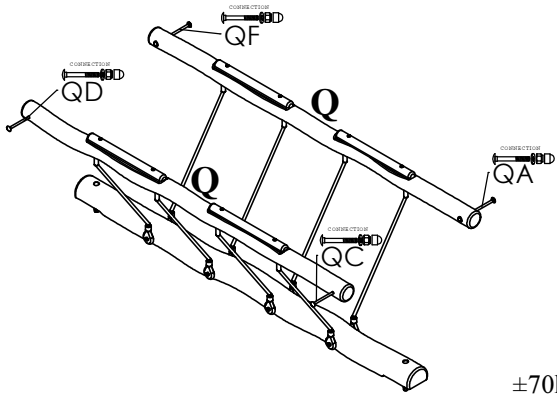
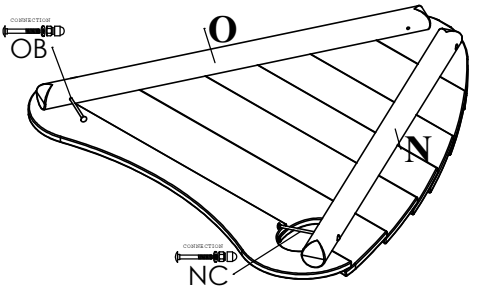
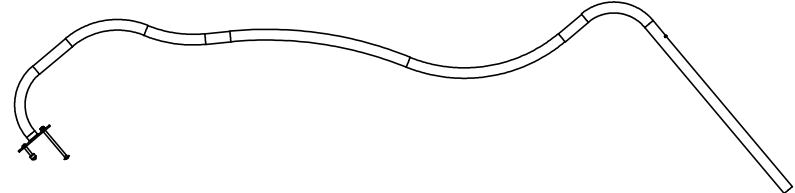
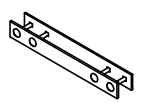
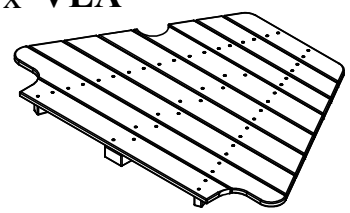
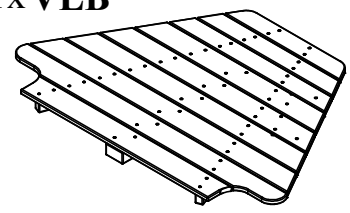
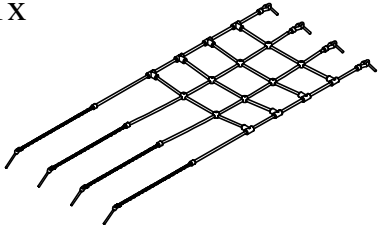
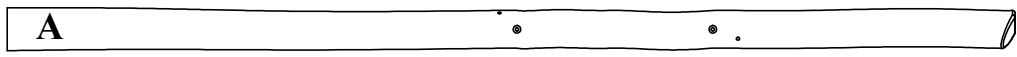
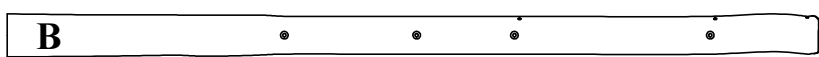
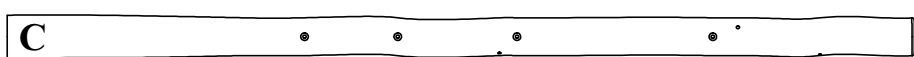
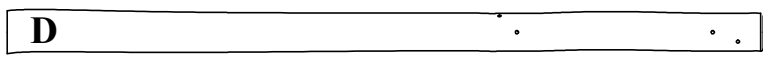
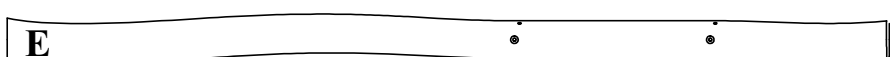
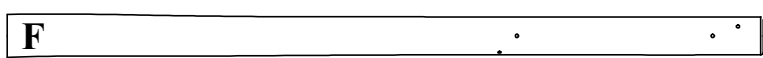
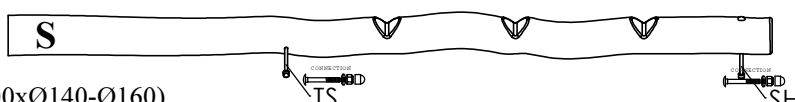



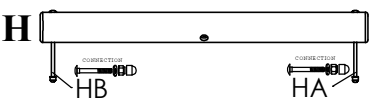
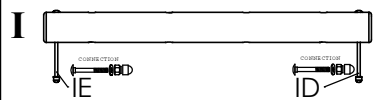
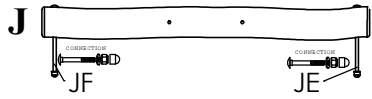
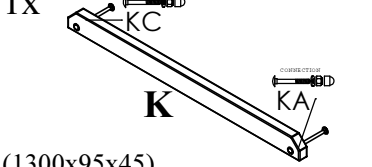
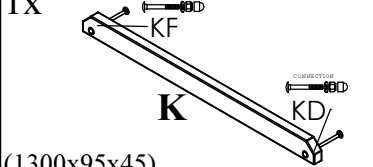
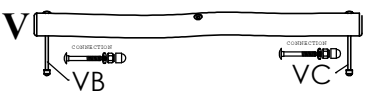

Samenvoegingszone RO691
Zone de liaison RO691
Verbindungsfeld RO691
Linking zone RO691
Zona de conexión RO691
Zona di allineamento RO691

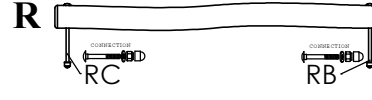
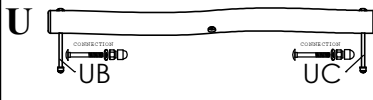
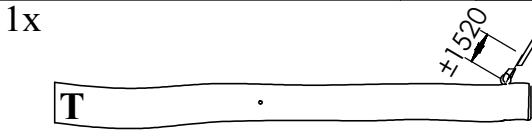
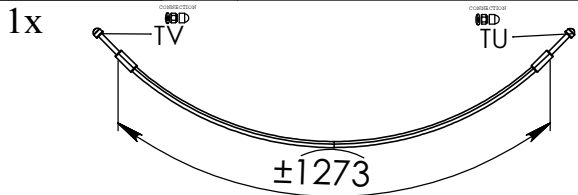
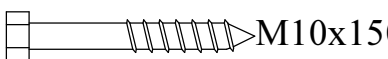
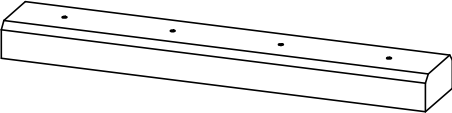
±52,5m²

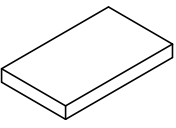
Benodigdheden - Liste des pièces - Materials - Benötigtes - Accesorios - Requisiti

<p>1x</p>  <p>±70kg</p>	<p>1x</p>  <p>±41kg</p>	
<p>2x</p>  <p>±12kg</p>		<p>1x</p> 
<p>1x VLA</p>  <p>±12kg</p>	<p>1x VLB</p>  <p>±12kg</p>	<p>1x</p> 
<p>1x</p>  <p>A</p> <p>(4000xØ140-Ø160)</p> <p>±61kg</p>		
<p>1x</p>  <p>B</p> <p>(3230xØ140-Ø160)</p> <p>±50kg</p>		
<p>1x</p>  <p>C</p> <p>(3600xØ140-Ø160)</p> <p>±55kg</p>		
<p>1x</p>  <p>D</p> <p>(3000xØ140-Ø160)</p> <p>±47kg</p>		
<p>1x</p>  <p>E</p> <p>(3500xØ140-Ø160)</p> <p>±54kg</p>		
<p>1x</p>  <p>F</p> <p>(3000xØ140-Ø160)</p> <p>±47kg</p>		
<p>1x</p>  <p>S</p> <p>(3000xØ140-Ø160)</p> <p>±46kg</p>		

Benodigdheden - Liste des pièces - Materials - Benötigtes - Accesorios - Requisiti

1x G  (1300xØ100-Ø120) ±12kg	1x H  (1300xØ100-Ø120) ±12kg	1x I  (1300xØ100-Ø120) ±12kg
1x J  (1300xØ100-Ø120) ±12kg	1x K  (1300x95x45)	1x K  (1300x95x45)
1x V  (1300xØ100-Ø120)	1x L  (1300xØ100-Ø120)	1x L  (1300xØ100-Ø120)
1x M  (1300xØ100-Ø120)	1x R  (1300xØ100-Ø120)	1x U  (1300xØ100-Ø120)
1x T  (1890xØ140-Ø160) ±29kg	1x  ±1273	
2x  M10x150	1x  (1200x200x100) ±15kg	
2x  M10	2x  (200x100x22)	
4x  M12		
4x  M10		
4x  M12		
4x  M12		
64x  4,5x50		

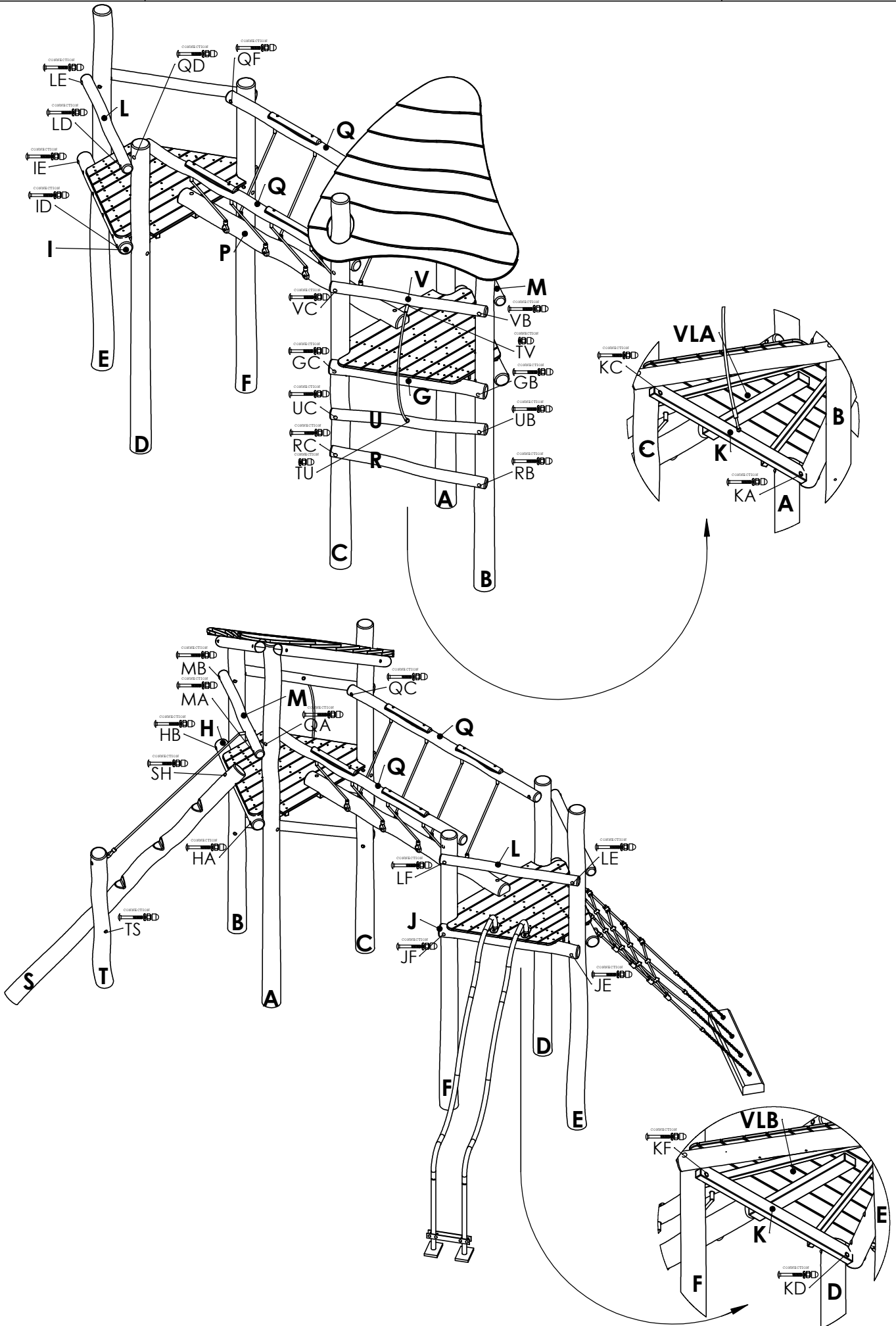

1

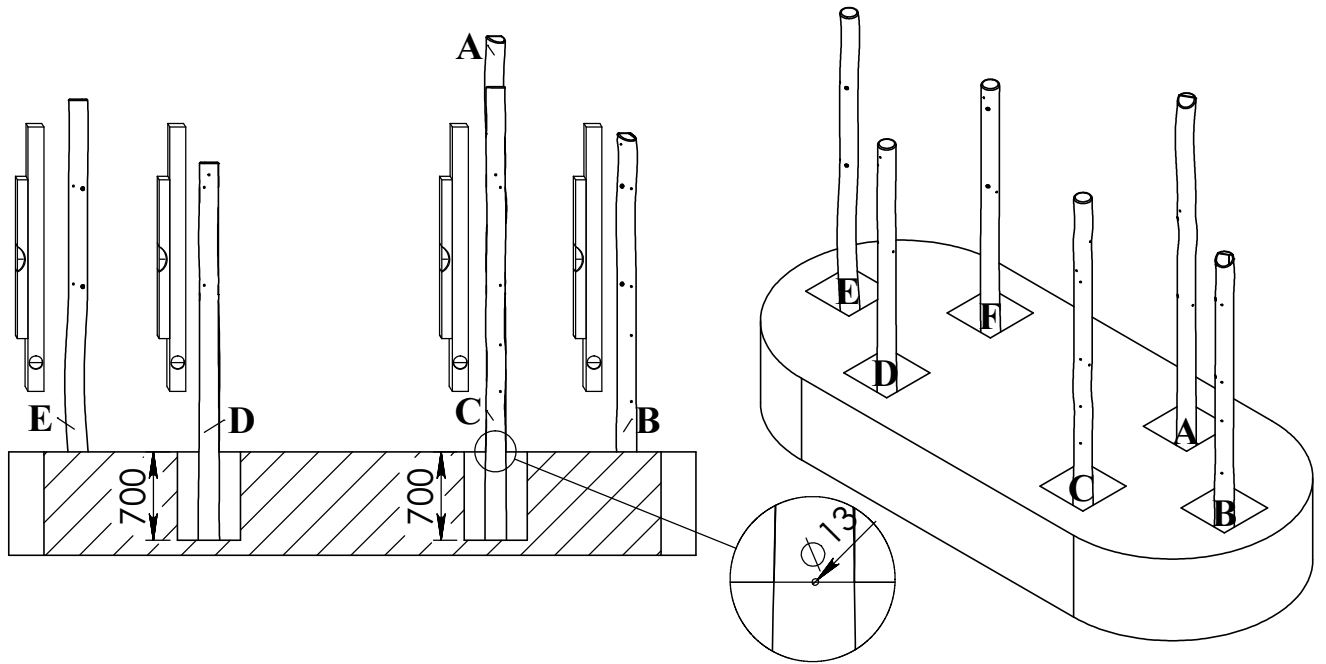

2

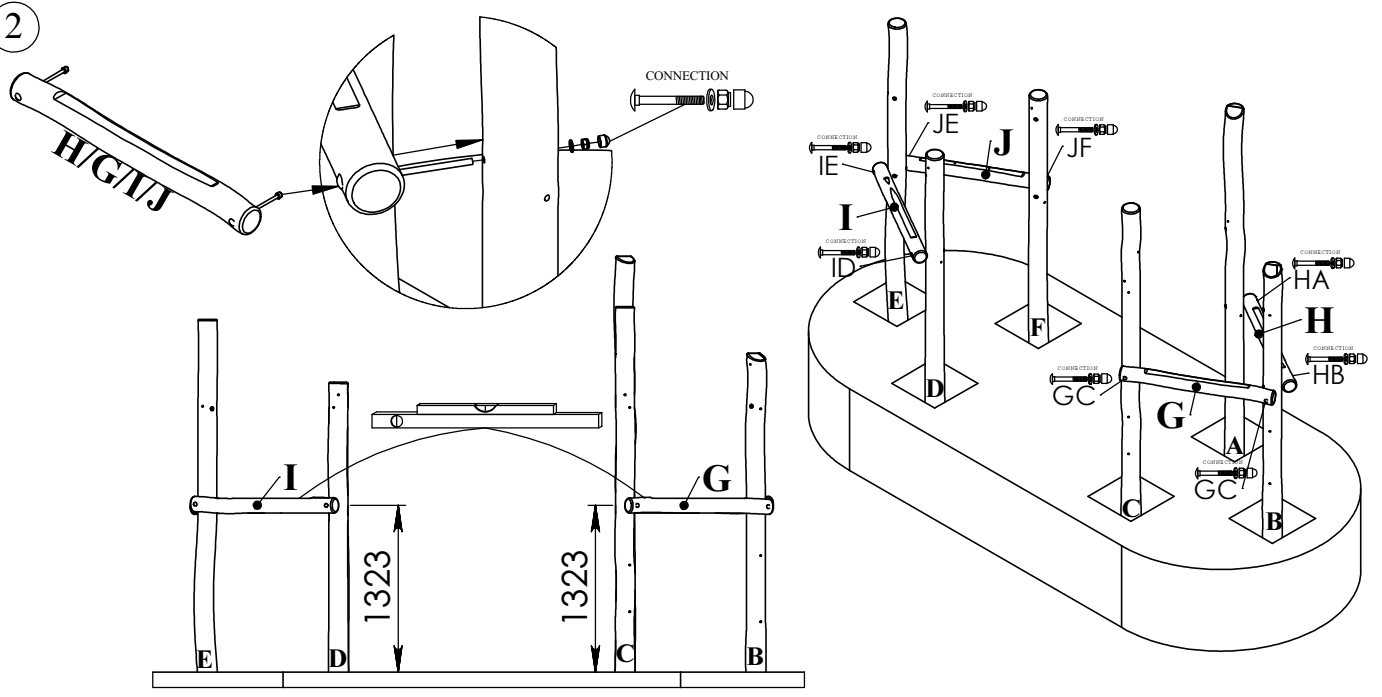

3

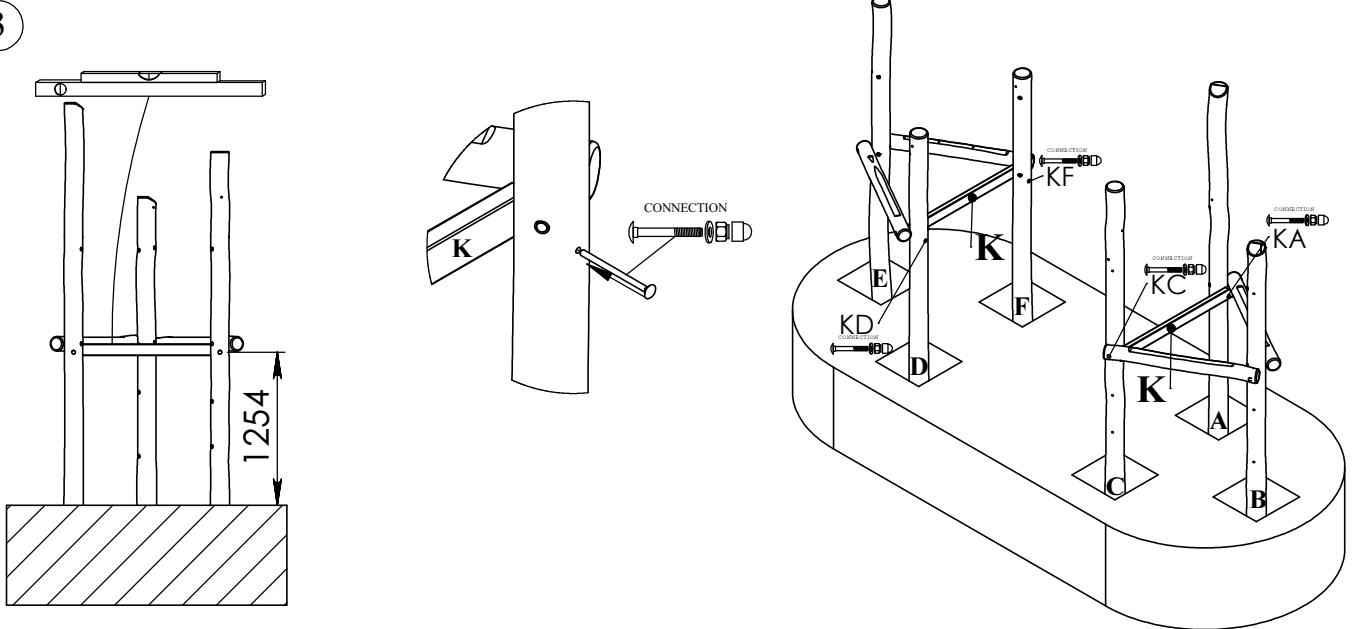

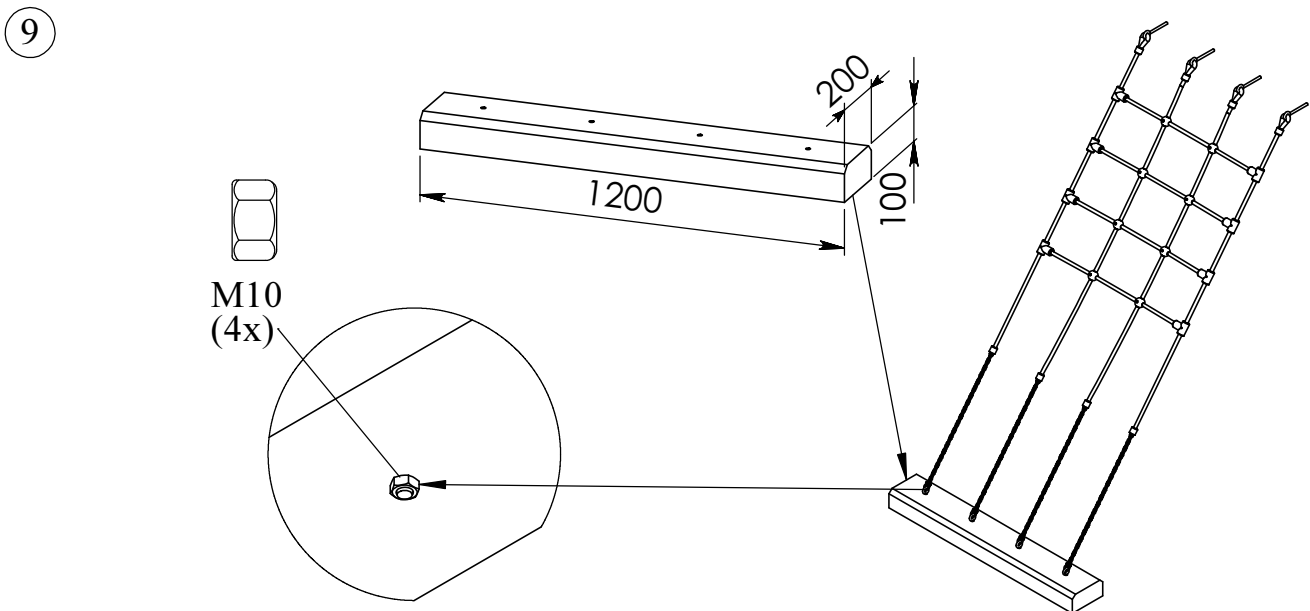
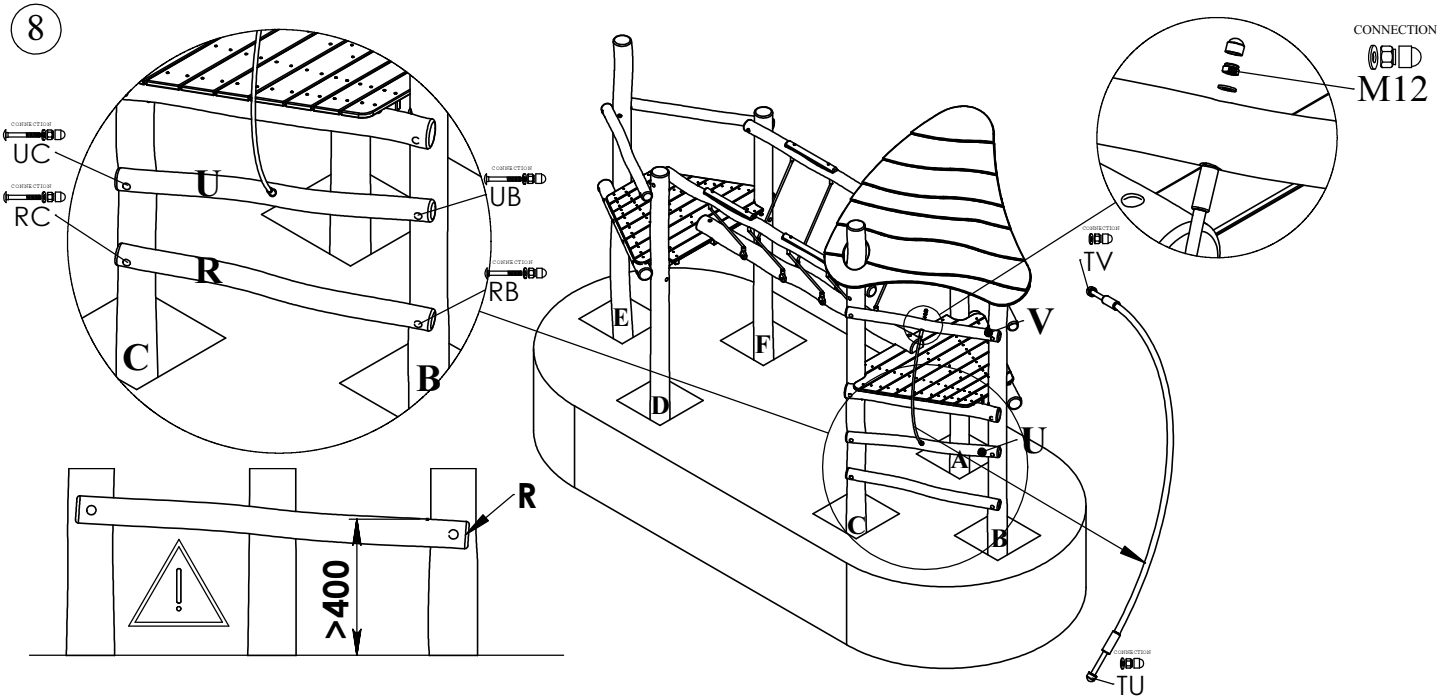
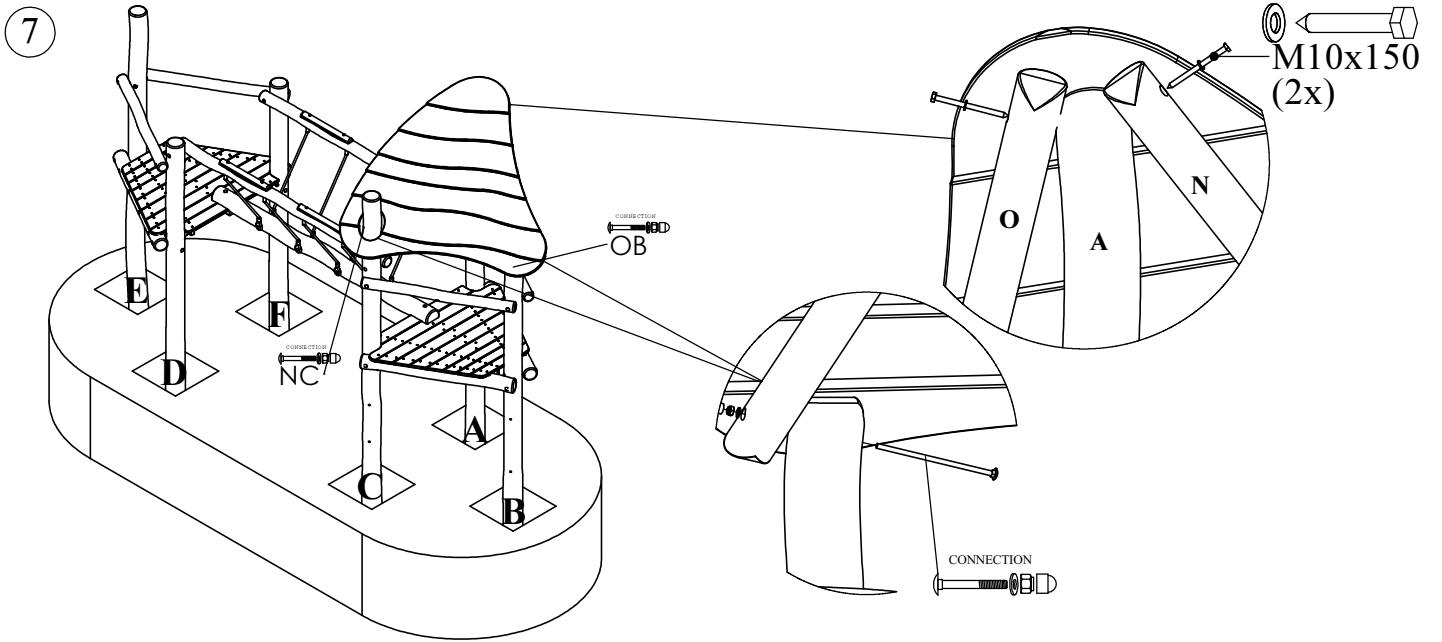

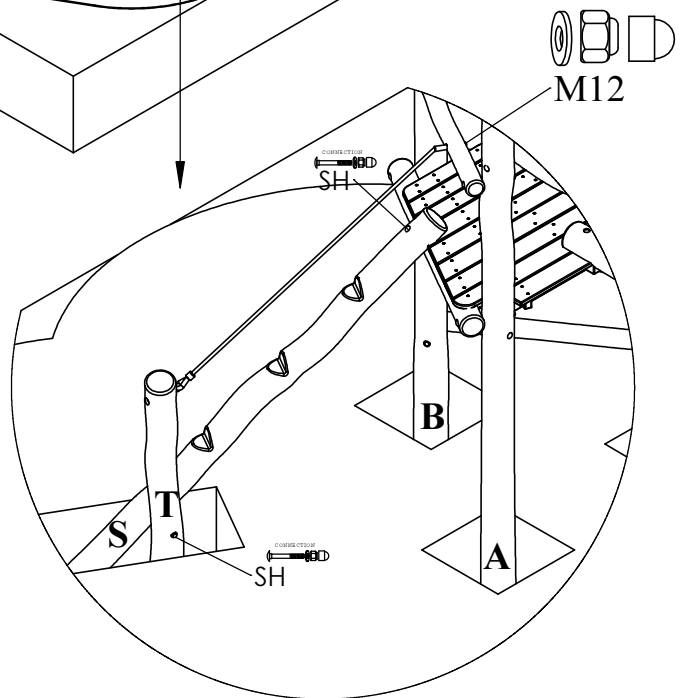
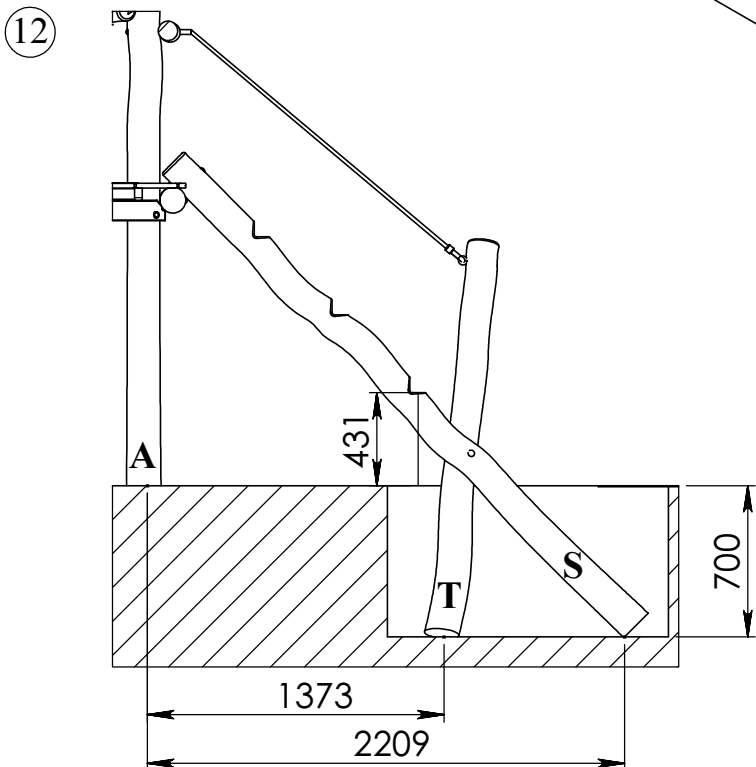
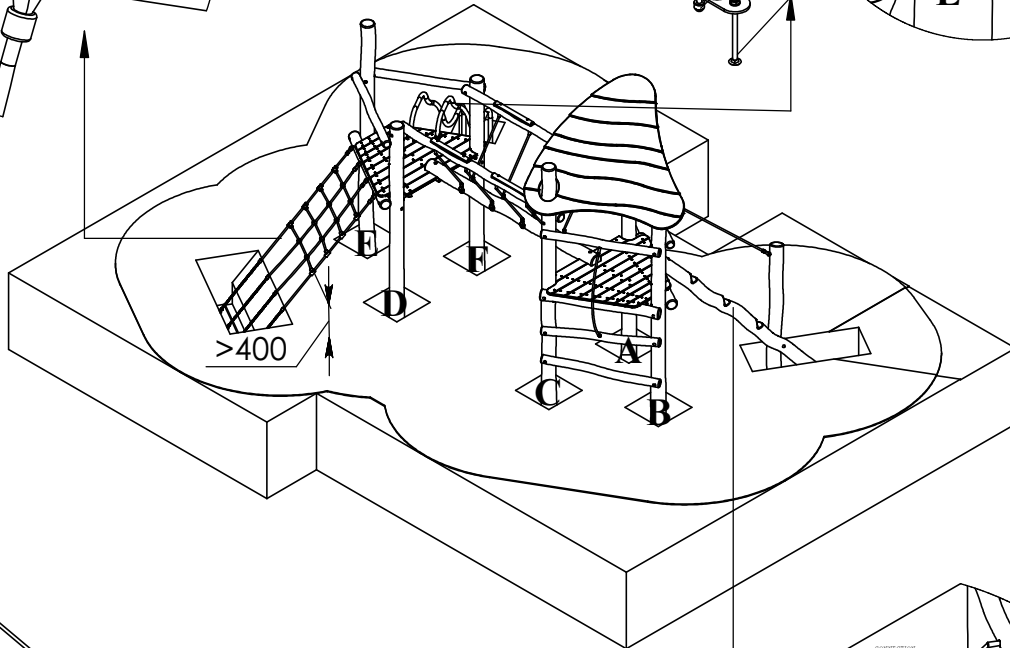
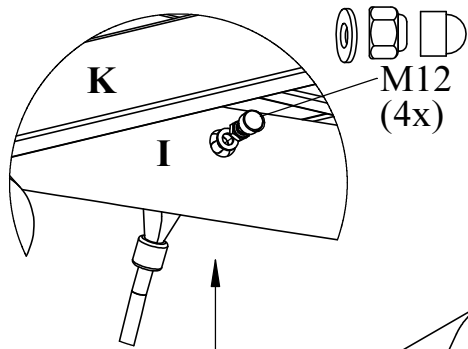
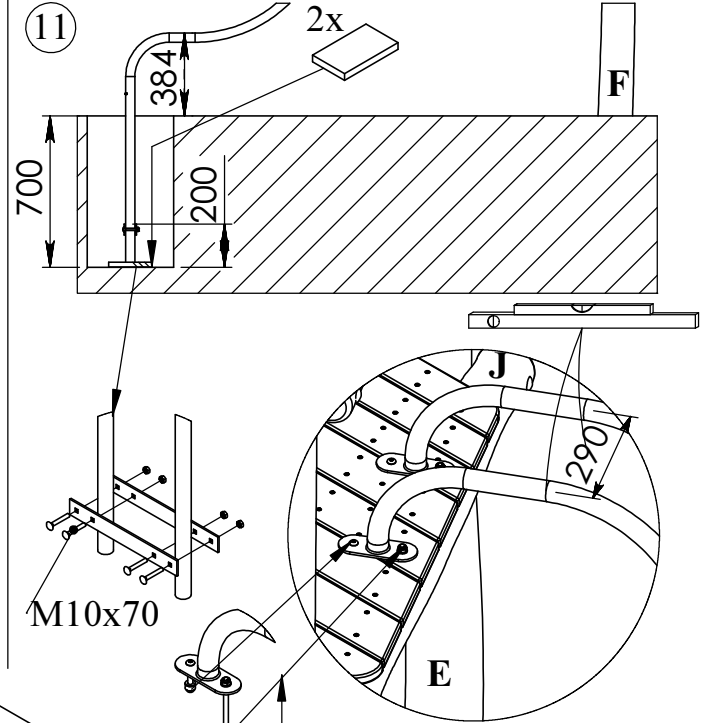
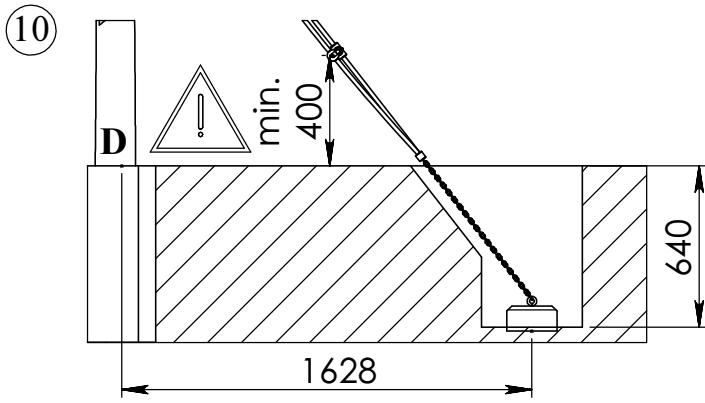

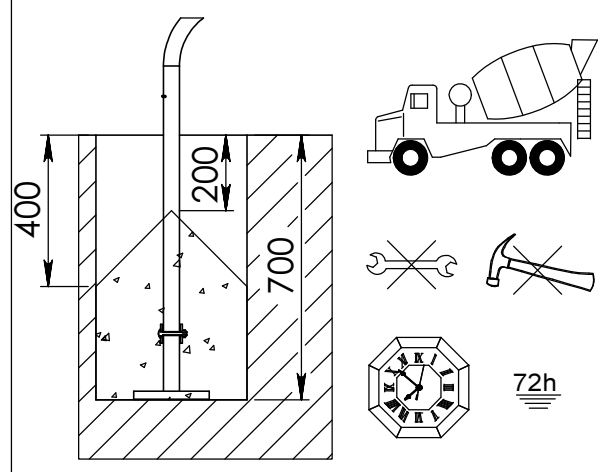
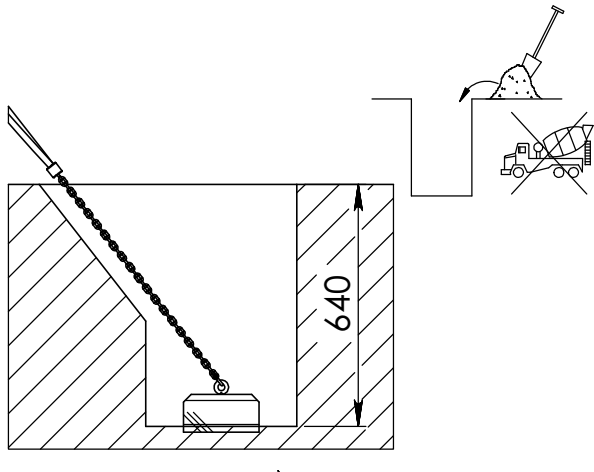

15

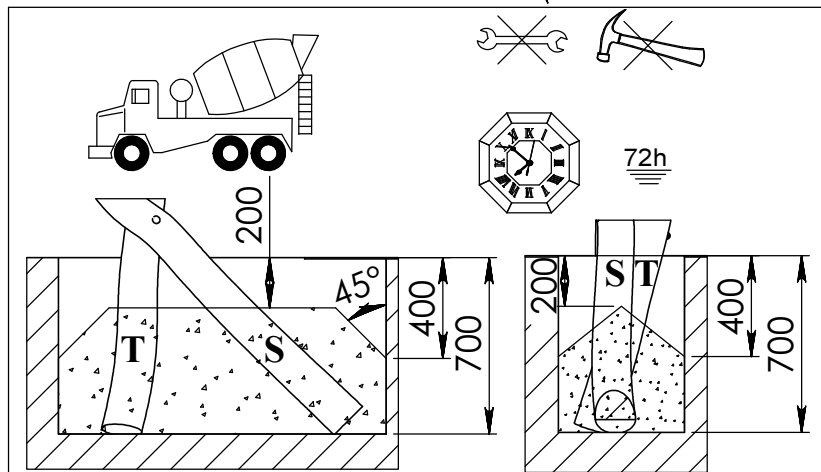
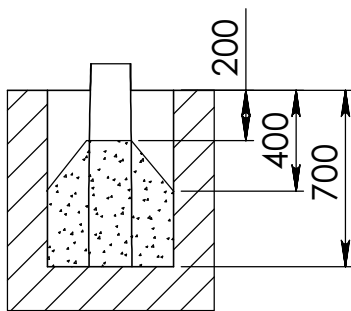
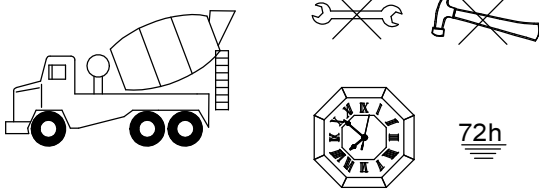
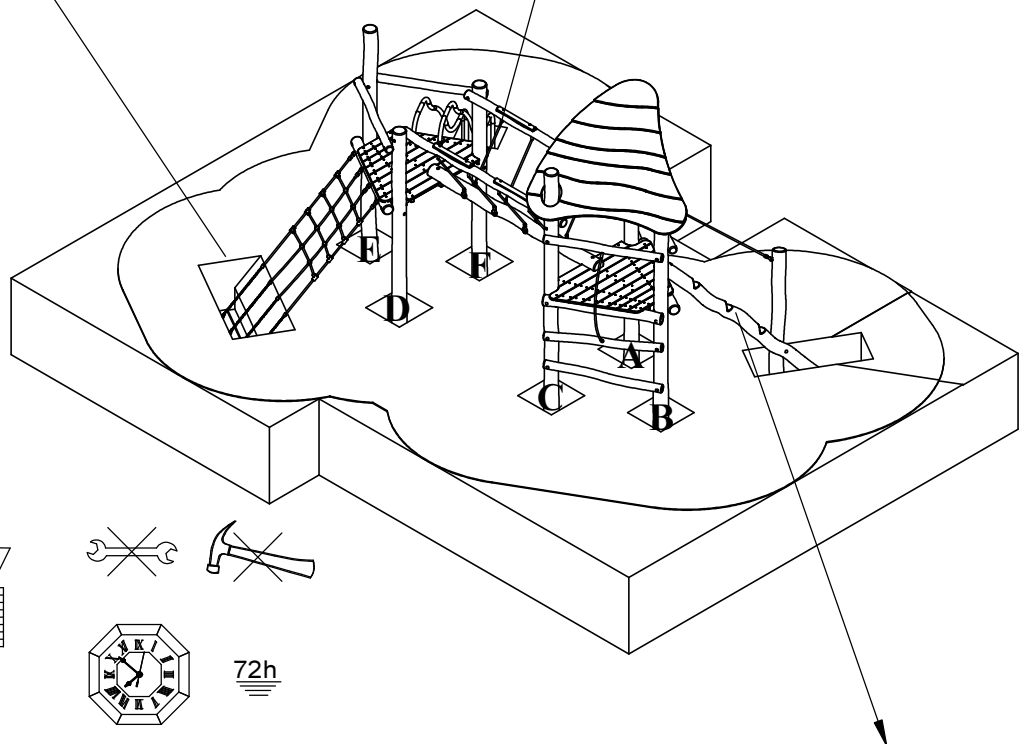

16

Bij droog weer moeten alle bouten en schroeven opnieuw aangespannen worden.
 Par temps sec il faut resserrer régulièrement toute la visserie.
 By dry and warm weather check the tightness of all bolts and screws.
 Bei trockenem Wetter müssen alle Schrauben und Bolzen aufs neue angespannt werden.
 Para el tiempo seco, se necesita cerrar o ajustar los tornillos y tuercas.
 Con tempo asciutto, tutti i bulloni e le viti devono essere avvitate nuovamente.