

STREET FITNESS SW+FI-004

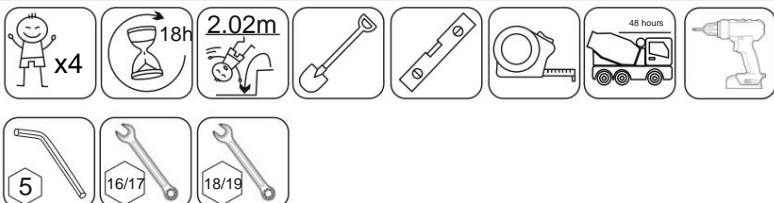

2026

ALL STAGES OF FOUNDATION AND ASSEMBLY MUST BE PHOTOGRAPHICALLY DOCUMENTED.
THE LACK OF PHOTOGRAPHIC DOCUMENTATION WILL AFFECT THE ISSUANCE OF THE WARRANTY CARD.



Examples of standard impact-absorbing materials, their thicknesses and their corresponding maximum free fall heights (according to EN 1176-1:2017)

MATERIAL ^[a]	DESCRIPTION	THICKNESS MINIMUM ^[b]	MAXIMUM HEIGHT FREE FALL
If the completed surface is verified (e.g. sieve test) in accordance with this Table or has a test report in accordance with EN 1177, no further tests are necessary.	mm	mm	mm
TURF / SOIL	-	-	less than or equal to 1,000 ^[d]
BARK	grain size from 20 to 80	200	less than or equal to 2,000
		300	less than or equal to 3,000
WOOD CHIPS	grain size from 5 to 30	200	less than or equal to 2,000
		300	less than or equal to 3,000
SAND OR GRAVEL ^[c]	grain size from 0.25 to 8	200	less than or equal to 2,000
		300	less than or equal to 3,000
OTHER MATERIALS AND OTHER THICKNESSES	According to EN 1177 testing		Critical fall height according to the study

^[a] For further information on specific materials suitable for use on playgrounds children's play areas see CEN/TR 16598 (Collection of justifications for the requirements of EN 1176-1)

^[b] For bulk material, add 100mm to the minimum depth to compensate for displacement (see 4.2.8.5.1)

^[c] Sand and gravel should be well rounded and washed to eliminate most silt or clay particles. Washed sand or gravel is considered to be from alluvial (naturally eroded) deposits and free from most silt or clay particles. Gravel may be commonly referred to as "cobble." The uniformity coefficient D60/D10 <3.0. Particle size can be determined using a sieve test according to EN 933-1 (see Annex G).

^[d] See NOTE2 in 4.2.8.5.2.

INSTALLATION / ASSEMBLY

ÿ Installation only in a place ensuring a minimum free area - the so-called impact surface; ÿ Installation of the device in accordance with the design documentation while maintaining the following conditions;

ÿ The distance of the device from windows of rooms intended for human occupancy, from roads and places intended for waste collection should be at least 10 meters;

ÿ Distance from the playground to parking spaces: a) 7 m for up to 4 spaces inclusive, b) 10m in the case of 5 to 60 stations inclusive, c) 20m in the case of more than 60 stations, ÿ Installation

in an undeveloped area; ÿ Installation outside the safety zone of existing devices;

Particular attention should be paid to: - vertical positioning of the posts, - horizontal positioning of the bars and crossbars; -tightening screws and other fasteners;

INSTRUCTIONS FOR INSPECTION AND MAINTENANCE OF THE DEVICE

INSPECTION AND MAINTENANCE INSTRUCTIONS FOR RESPONSIBLE PERSONS FOR SAFETY IN THE RECREATIONAL AND SPORTS AREA

Daily inspection of the area, during which attention should be paid to: ÿ cleanliness of the area (all rubbish and items not belonging to the equipment of the square should be removed

playgrounds); ÿ clearances between the device and the ground; ÿ condition of the ground surface; ÿ shifted foundations; ÿ finishing of smoothed surfaces; ÿ missing and broken parts; ÿ condition of individual element connections.

Weekly inspection: ÿ

checking the condition of screw connections - tighten if loose; ÿ checking the condition of wooden surfaces - remove splinters if damaged.

Monthly inspection should include: ÿ checking

the functionality and stability of the device, tightening the screw connections if necessary occur;

ÿ supplementing the loose materials filling the area of the fall surface up to the base level mark placed on the device.

The inspection carried out at least **once a year** should include: ÿ inspection

of the technical condition and technical tests by the manufacturer's representative as part of concluded contract;

ÿ supplementing and levelling of soil and grass surfaces in the most exposed and intensively used areas; ÿ after each inspection, any irregularities found should

be immediately rectified or the use of faulty equipment should be prevented from being used until it is repaired; ÿ records of all actions taken as part of safety supervision

should be kept in the equipment inspection and control book.

NOTE: The annual main inspection may require the unearthing or disassembly of parts of the unit.

REPLACEMENT OF WORN OR DAMAGED COMPONENTS

Metal parts of the device, connecting elements, and other components of the device are subject to replacement. If damage is detected, the following should be done: ÿ Secure the device from users until it is removed by fencing it.

ÿ construction warning tape with a suspended board informing about the damage;

ÿ dismantle the damaged part of the device that poses a risk to playing children, e.g.: exposed parts of metal connectors, etc. ÿ during repairs, replace

damaged or worn parts with identical ones supplied by the product

manufacturer; ÿ if necessary, contact the device manufacturer's service center.

INSTRUCTIONS FOR INSPECTION AND MAINTENANCE OF THE DEVICE

In the area where the devices are installed, a board should be placed containing: ÿ the regulations for using the device; ÿ the telephone numbers of the fire brigade (998), ambulance service (999), police (997), site supervisor and the emergency number 112; ÿ all entrances and passages intended for users of the area and emergency services. must be constantly available, free from any obstacles.

INSTRUCTIONS - DEADLINE TESTING

After the device is installed, jam tests should be performed to verify correct installation. All tests should be performed under the most unfavorable conditions.
Instructions prepared on the basis of the **EN 1176 1:2017** standard (Part 1: General safety requirements and test methods).

- 1 Perform **head and neck** entrapment testing using probes/templates in fully enclosed, partially enclosed and V-shaped openings according to procedure **D.2.1.2** and **D.2.2.2**.
- 2 Perform a **clothing** entrapment test using a testing device/button/chain in accordance with procedure **D. 3.2.** on tested devices such as: slides, fireman's poles, canopies.
- 3 Perform a **finger** pinch test using the finger probe according to procedure **D.4.2**.
- 4 Test **the chain holes** using a chain tester according to procedure **D.5.2**.
- 5 Perform an examination/measurement of devices that may cause **whole body** entrapment based on point **4.2.7.4**.
- 6 Perform an examination/measurement of gaps that may cause **foot or leg** entrapment based on point **4.2.7.5**.

A review of possible pinch situations should be carried out based on Table **E.1** (Annex E of EN 1176-1:2017)

FOUNDATION STAGES

1 PREPARING THE SUBSTRATE FOR THE DEVICE TO BE MOUNTED

1.1. Based on the foundation dimensions (provided in the instructions), dig a foundation trench to the appropriate width and depth.

1.2. The bottom of the trench should be leveled and compacted (it should form a stable base for the foundations).

2 PLACING THE DEVICE IN THE TRACKS AND INSTALLING IT

2.1. The device poles must be placed in excavations.

2.2. Assembling the entire set (aligning the verticals and horizontals using a spirit level).

2.3. The poles placed in the trench are poured with a previously prepared concrete mixture (concrete class minimum C12/15).

3 PROTECTING THE DEVICE AGAINST USE

3.1. The device must be secured against use until the foundations have set (their appropriate strength parameters have been achieved).

3.2. After the concrete has set, the excavations should be backfilled with a layer of soil to the ground level in accordance with the documentation (the ground level should be marked on the posts).

3.3. Once the device is fully assembled and stabilized, remove the safety device.

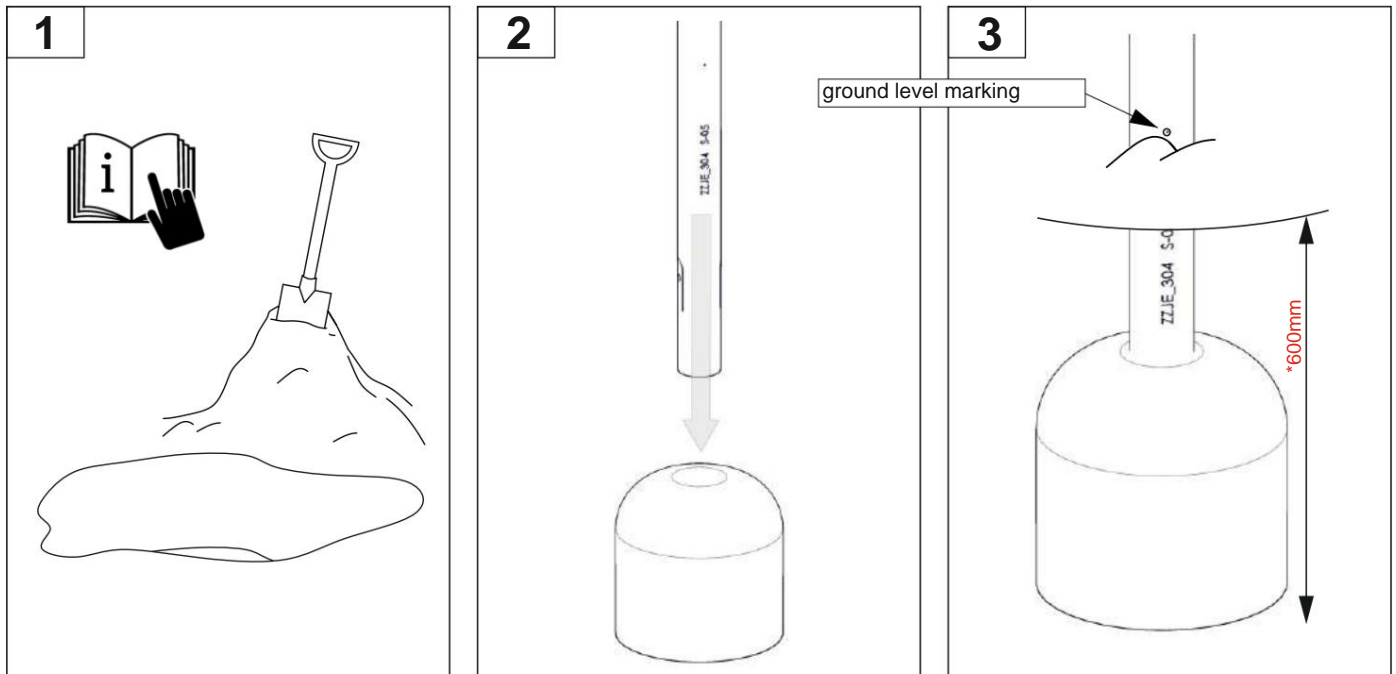

*the depth of the excavation and foundation should be made according to the basic foundation (individual foundations included in the instructions)

ALL STAGES OF FOUNDATION AND ASSEMBLY MUST BE PHOTOGRAPHICALLY DOCUMENTED.

THE LACK OF PHOTOGRAPHIC DOCUMENTATION WILL AFFECT THE ISSUANCE OF THE WARRANTY CARD.

BASIC FOUNDATION

FOUNDATION SHAPES

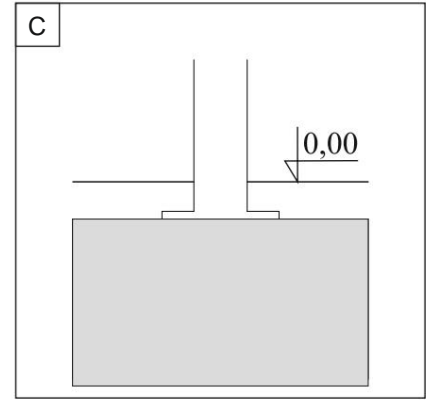
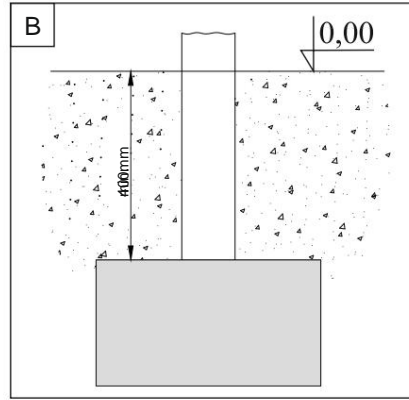
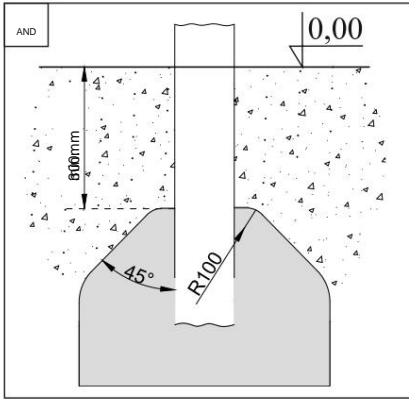

A The **FOUNDATION** has R100 roundings - the minimum distance is **300 mm** below the ground;

B The **FOUNDATION** has no roundings, the minimum distance is **400 mm** (for loose surfaces: sand, gravel, etc.); **C** **FOUNDATION**

with a foundation slab (safe surface - SBR).

MEASUREMENT OF FOUNDATIONS IN PLAYGROUNDS AND OUTDOOR GYMS

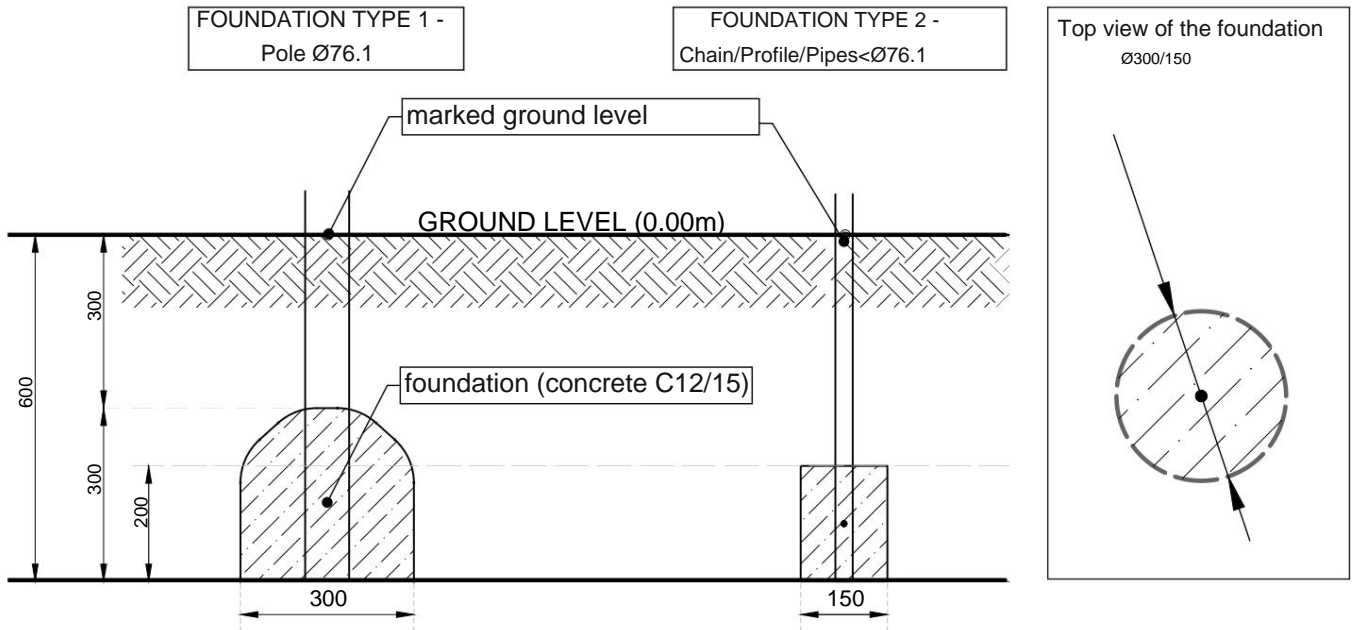

**Foundation in a trough (the basic foundation dimensions are increased by 300mm)*

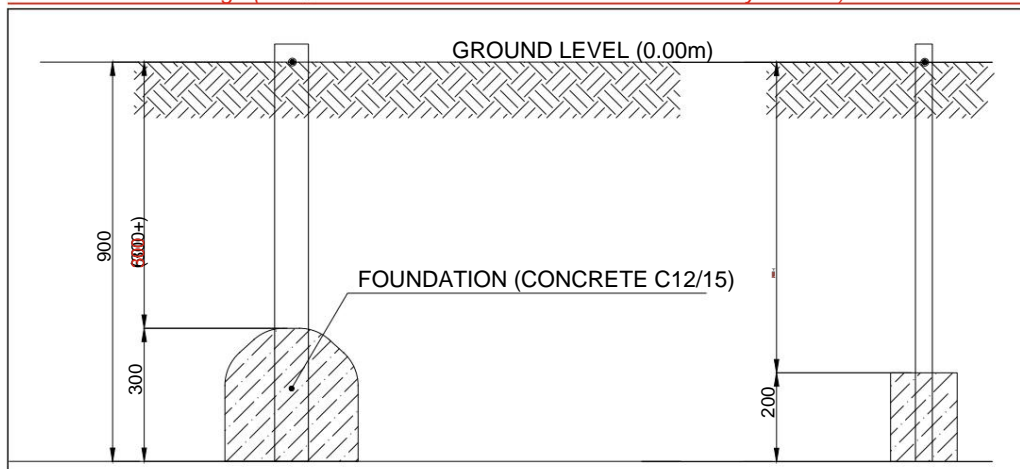

NOTE! Foundations for columns larger than 76.1 mm should be carried out according to individual instructions or technical documentation.

*Dimensions given in units [mm]

SIMBA[®]
Group

FALL SPACE RANGE

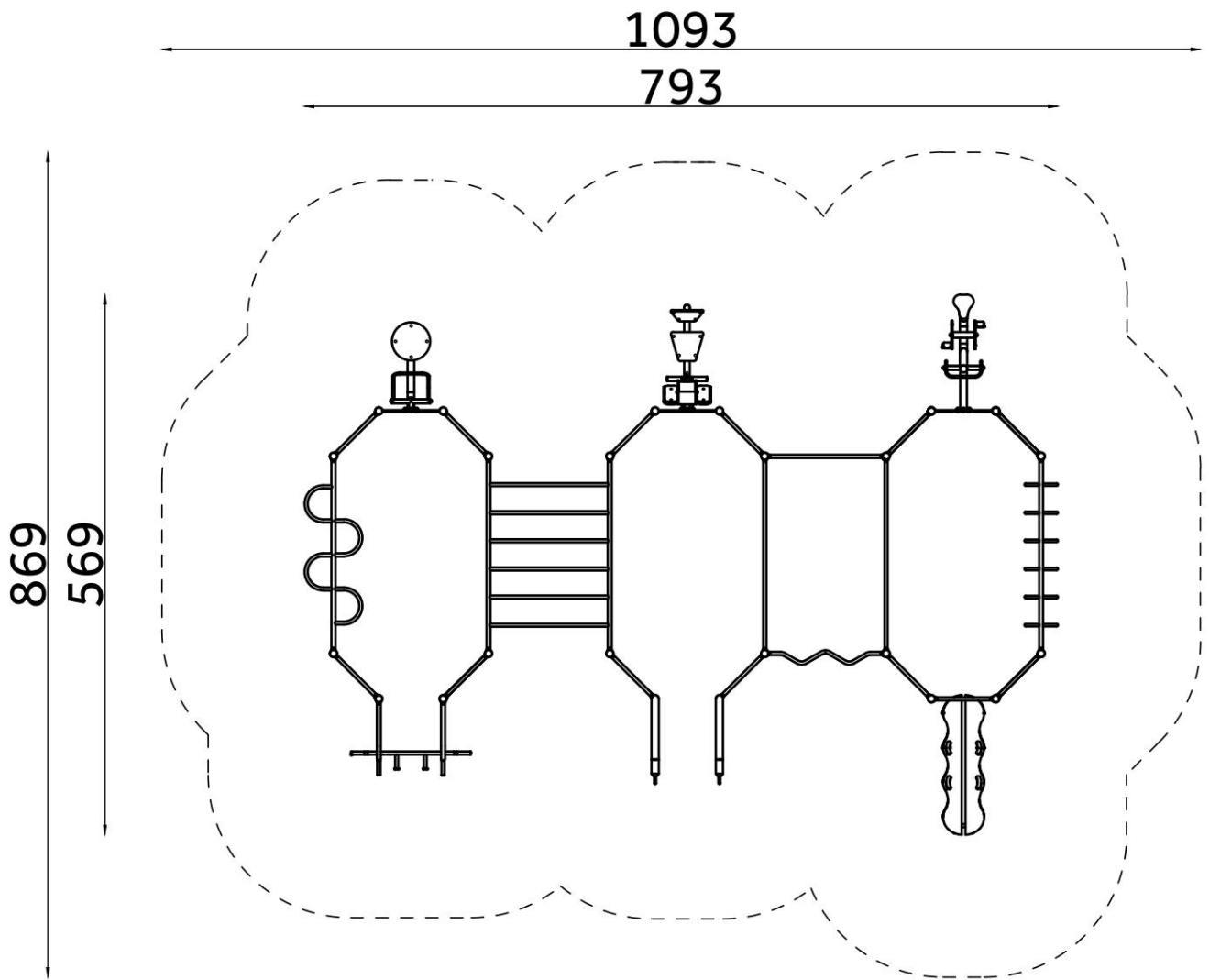

DEVICE ARRANGEMENT

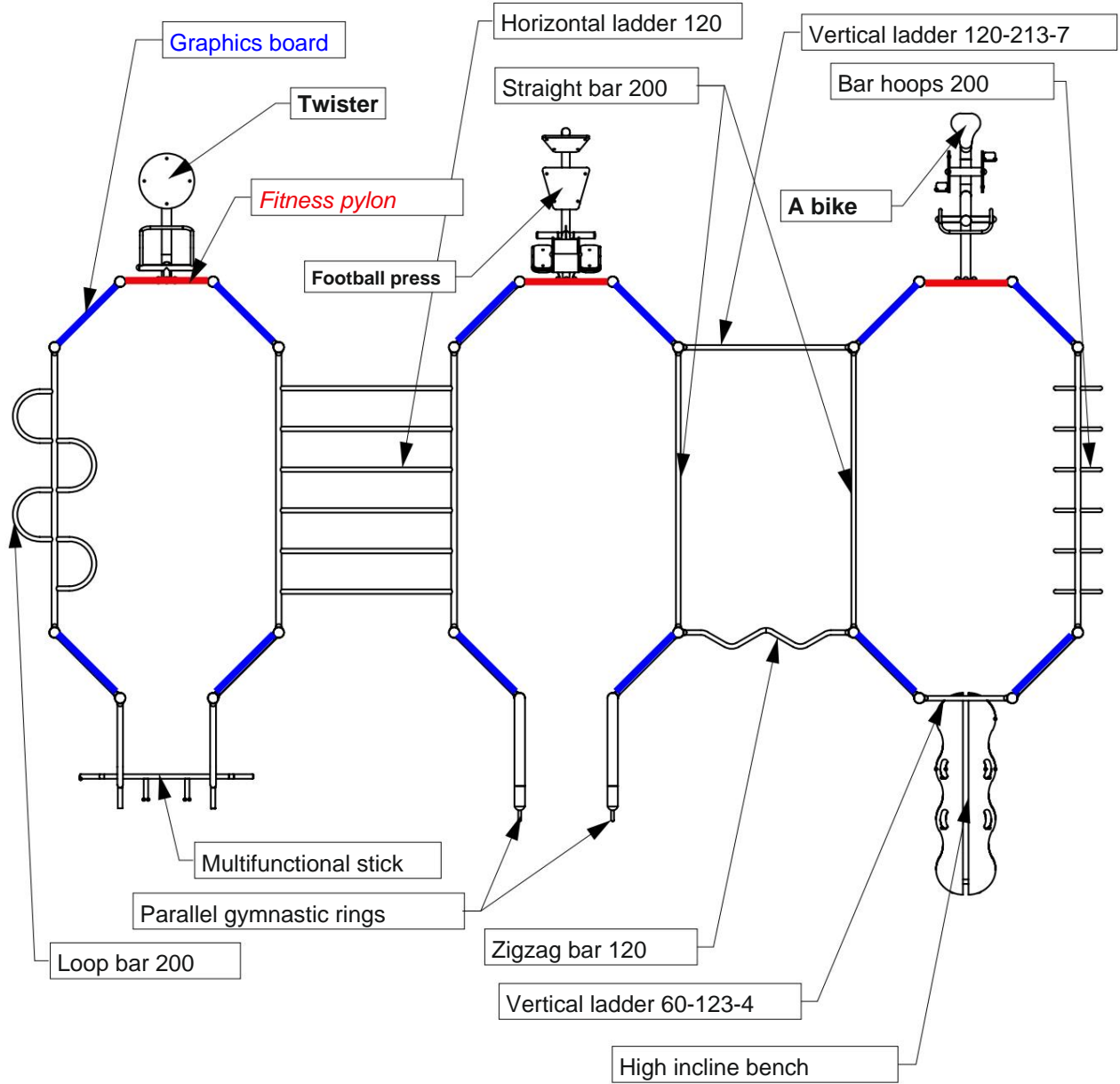

SIMBA[®]
Group

LIST OF SET COMPONENTS

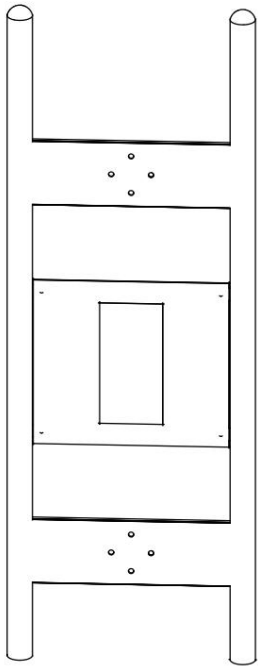

SW-050 Fitness pylon 3 pcs.

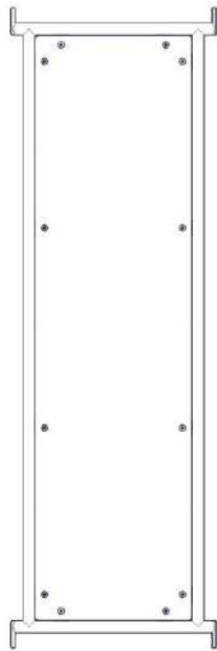

SW-052 Graphics Board
12 pcs.

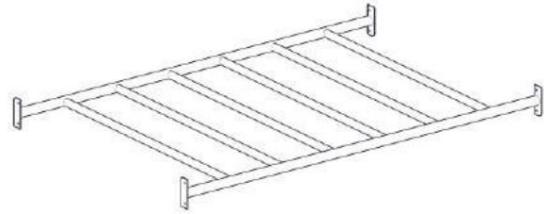

SW-015 Vertical ladder 120 1 pc.

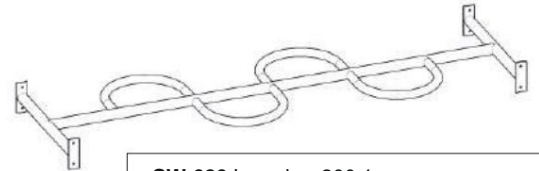

SW-020 Loop bar 200 1 pc.

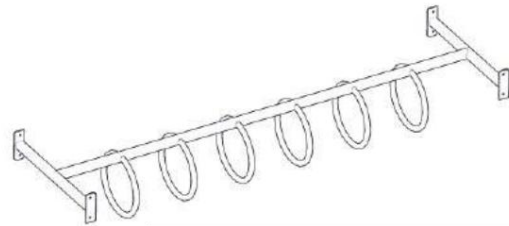

SW-023 Bar hoops 200 1 pc.



SW-014-4 Vertical ladder 60-123-4
1 pc.

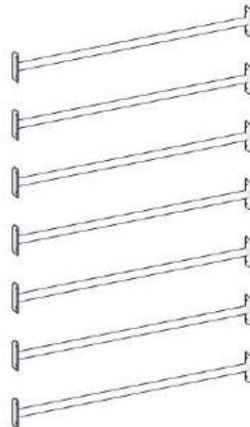

SW-013-7 Vertical ladder 120-213-7
1 pc.

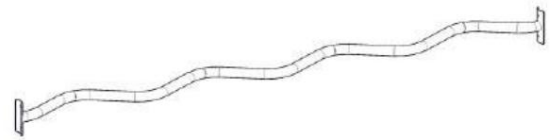

SW-031 Zigzag rod 120 1 pc.

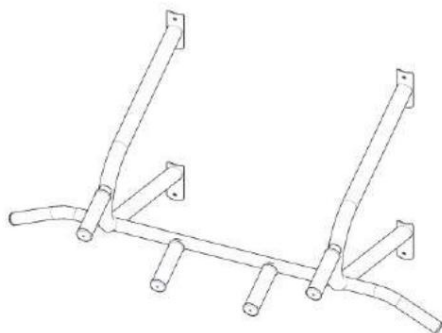

SW-026 Multifunctional stick 1 pc.



SW-027 Straight bar 200 2 pcs.

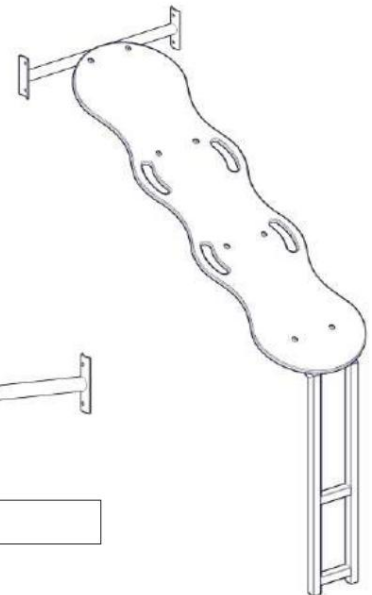

SW-034
High incline bench 1 pc.











NOTE! Before assembly, check the number of individual components included in the kit.

NOTE! The number of mounting elements may not match the list (individual components of the set are assembled before shipping to the customer)

LIST OF SET COMPONENTS

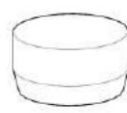

LIST OF FASTENING ELEMENTS

			
DIN 7380-2 M8x30 Allen screw with washer head	ISO 4017/DIN 933 M12x40 Hexagon head screw 20	ISO 4017/DIN 933 M10x100 Hexagon head screw 82	DIN 125 A10.5 Round flat washer
48 pcs.	pcs.	pcs.	166 pcs.
			
ISO 10511 M10 Nut locking hexagonal	ISO 10511 M12 Self- locking hexagon nut self-locking	ISO 4032 M10 Hexagonal nut	CAP CONCAVE M8
82 pcs.	20 pcs.	2 pcs.	48 pcs.
			
CAP CONCAVE M12	FLAT CAP M12	CAP CAP M8	CAP CAP M12
168 pcs.	40 pcs.	48 pcs.	42 pcs.

NOTE! Before assembly, check the number of individual components included in the kit.

NOTE! The number of mounting elements may not match the list (individual components of the set are assembled before shipping to the customer)

INSTALLATION OF GRAPHIC BOARDS TO PYLONS AND POLE SW-052

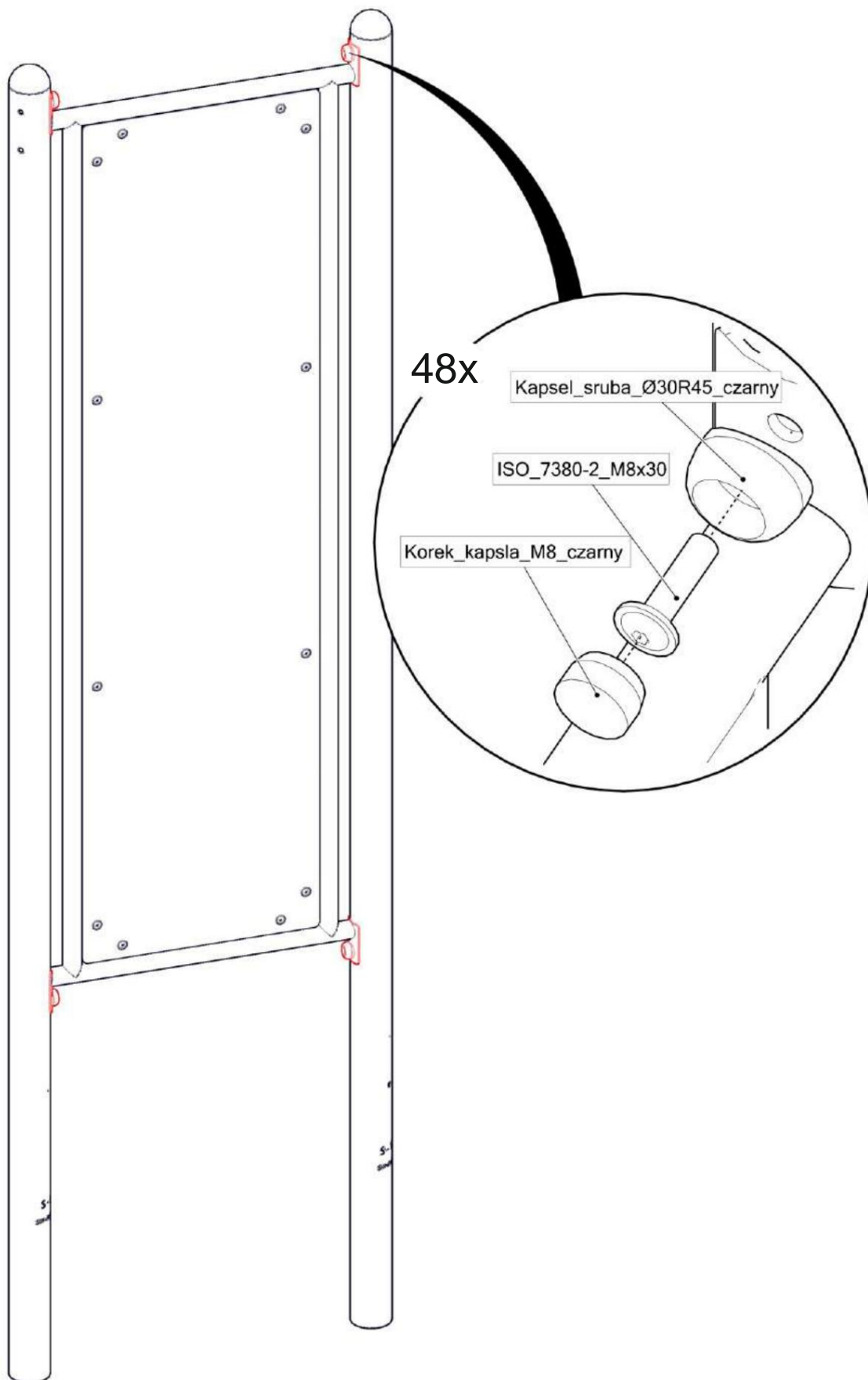

ALL STAGES OF FOUNDATION AND ASSEMBLY MUST BE PHOTOGRAPHICALLY DOCUMENTED.
THE LACK OF PHOTOGRAPHIC DOCUMENTATION WILL AFFECT THE ISSUANCE OF THE WARRANTY CARD.



SIMBA[®]
Group

INSTALLATION OF LOOPS/HOOPS/ZIGZAG/STRAIGHT BARS

SW-020, SW-023, SW-030, SW-027

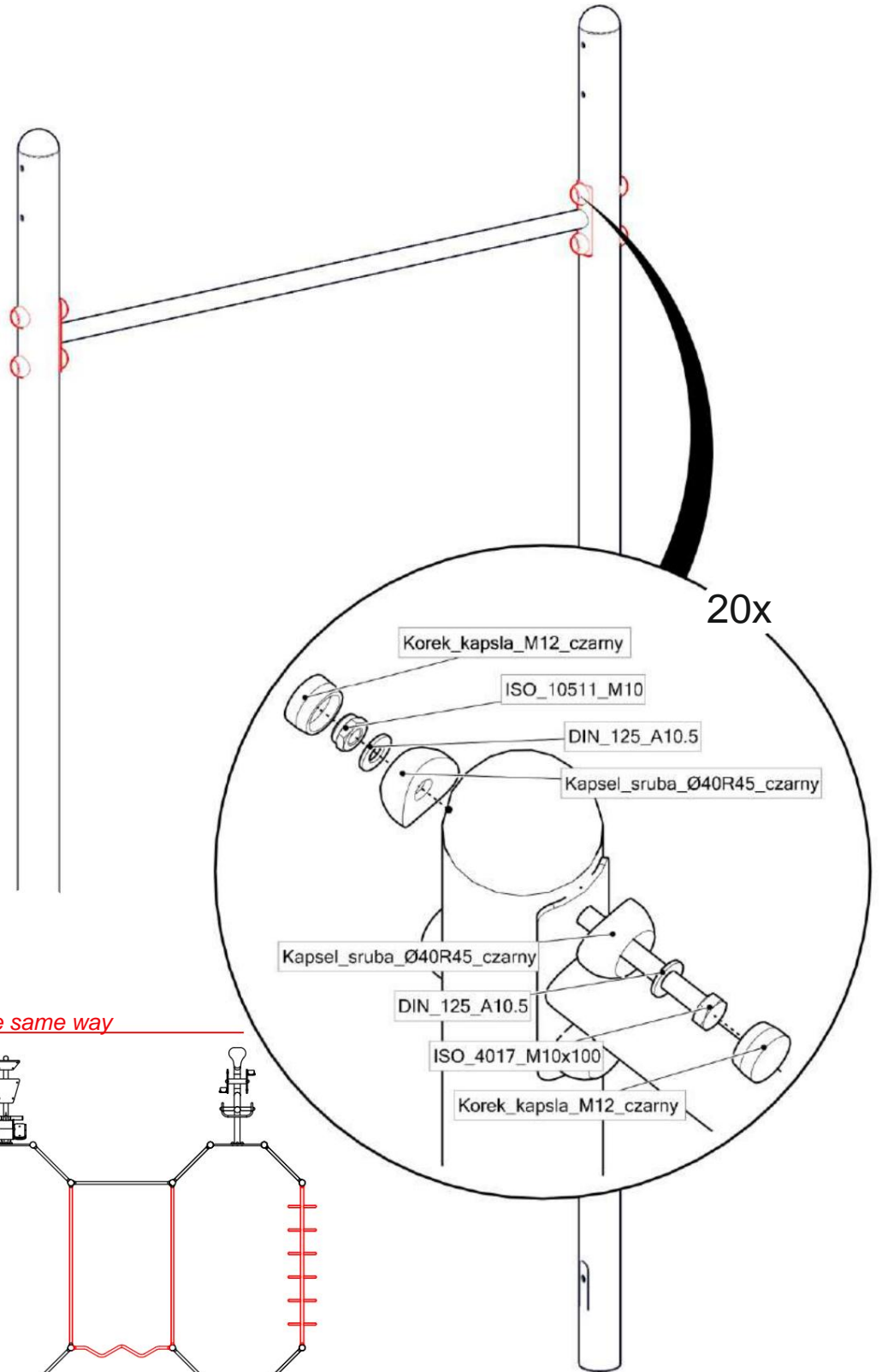

**All rods must be installed in the same way*

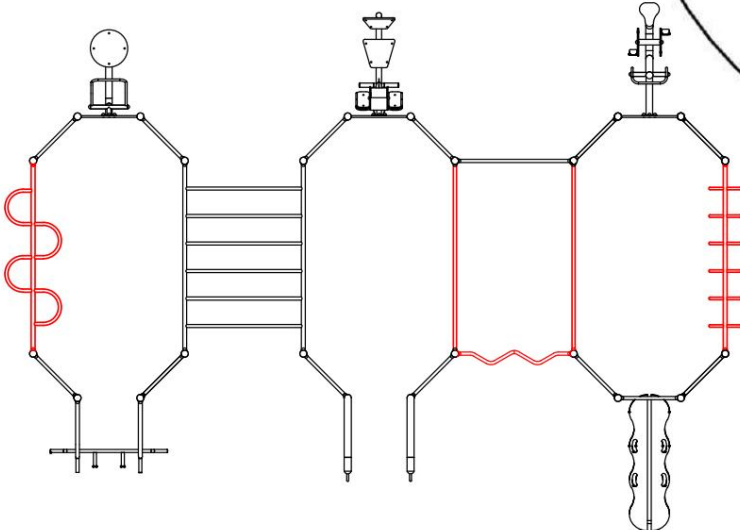

ALL STAGES OF FOUNDATION AND ASSEMBLY MUST BE PHOTOGRAPHICALLY DOCUMENTED.
THE LACK OF PHOTOGRAPHIC DOCUMENTATION WILL AFFECT THE ISSUANCE OF THE WARRANTY CARD.



INSTALLATION OF VERTICAL AND HORIZONTAL LADDERS



Przy montażu należy zwrócić uwagę na stronę przymocowania łuski

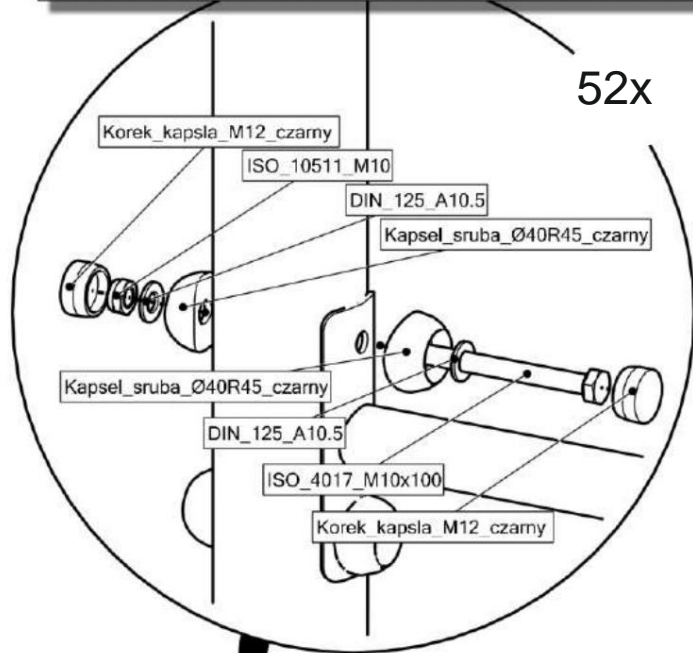

52x

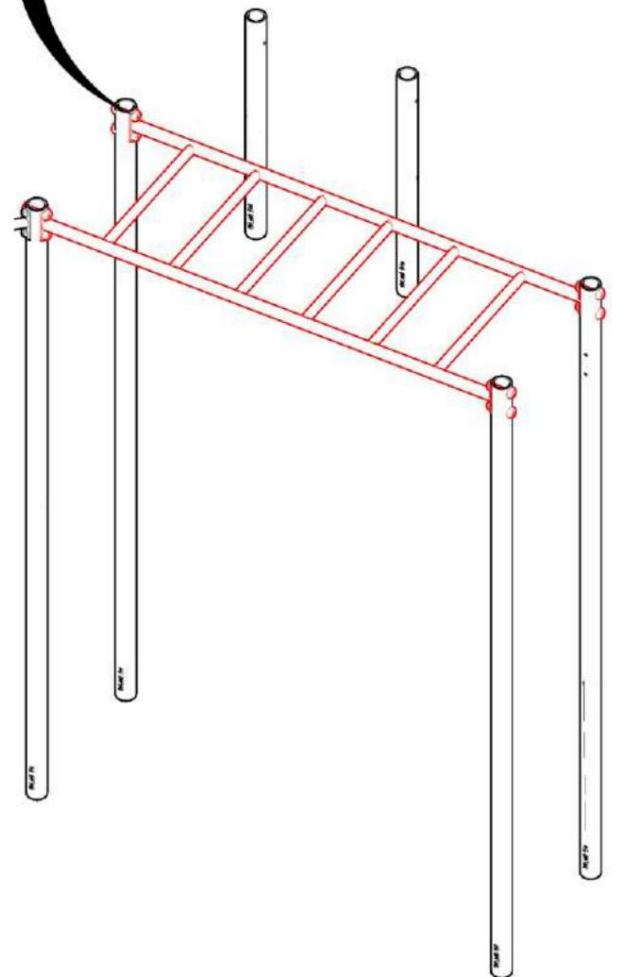

**All ladders must be assembled in the same way*

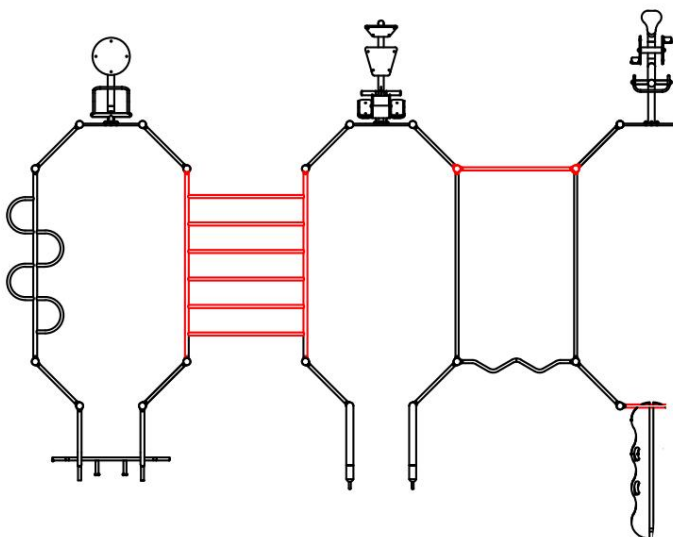

ALL STAGES OF FOUNDATION AND ASSEMBLY MUST BE PHOTOGRAPHICALLY DOCUMENTED.
THE LACK OF PHOTOGRAPHIC DOCUMENTATION WILL AFFECT THE ISSUANCE OF THE WARRANTY CARD.



SIMBA[®]
Group

INSTALLING THE MULTIFUNCTIONAL STICK

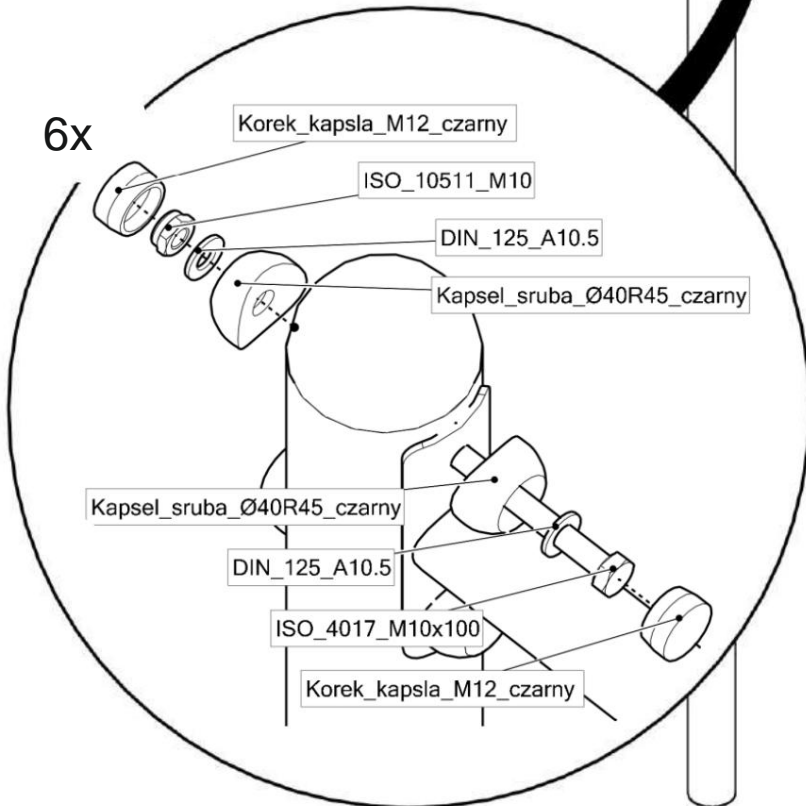
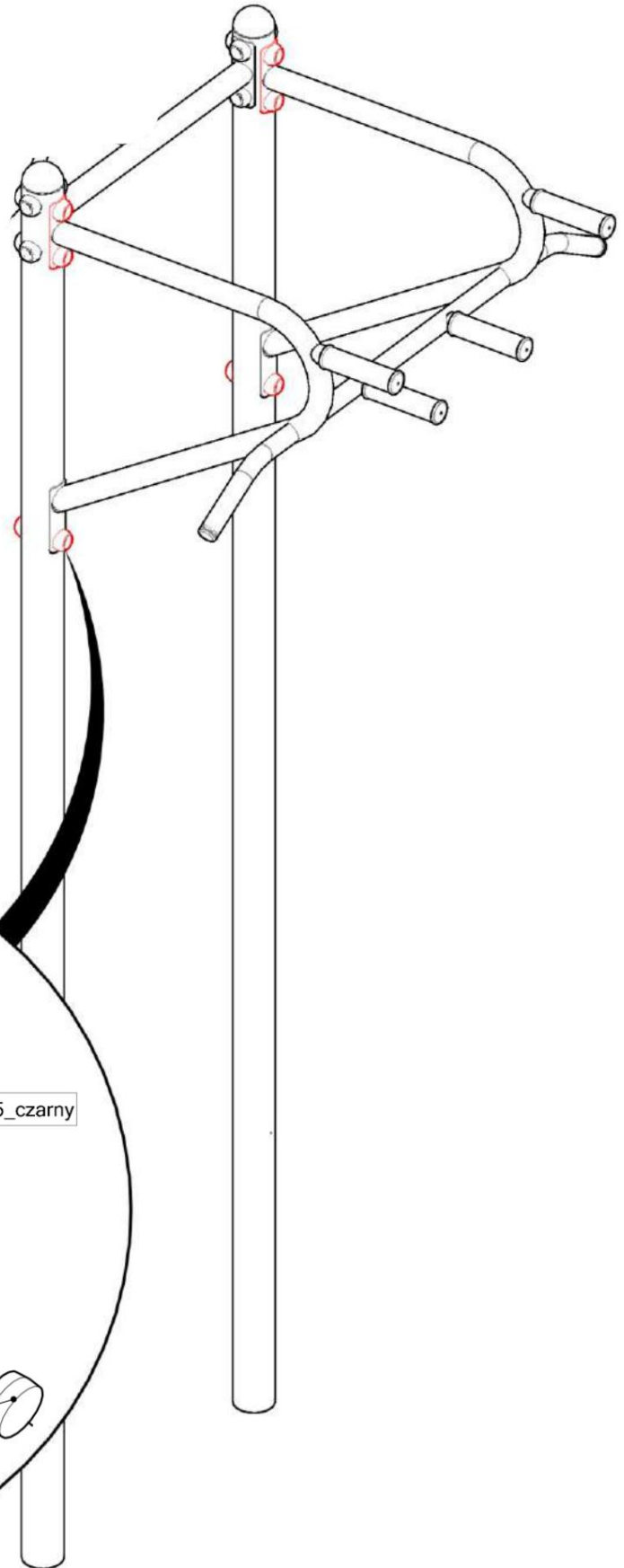

ALL STAGES OF FOUNDATION AND ASSEMBLY MUST BE PHOTOGRAPHICALLY DOCUMENTED.

THE LACK OF PHOTOGRAPHIC DOCUMENTATION WILL AFFECT THE ISSUANCE OF THE WARRANTY CARD.



SIMBA[®]
Group

INSTALLATION OF THE HIGH INCLINED BENCH SW-034

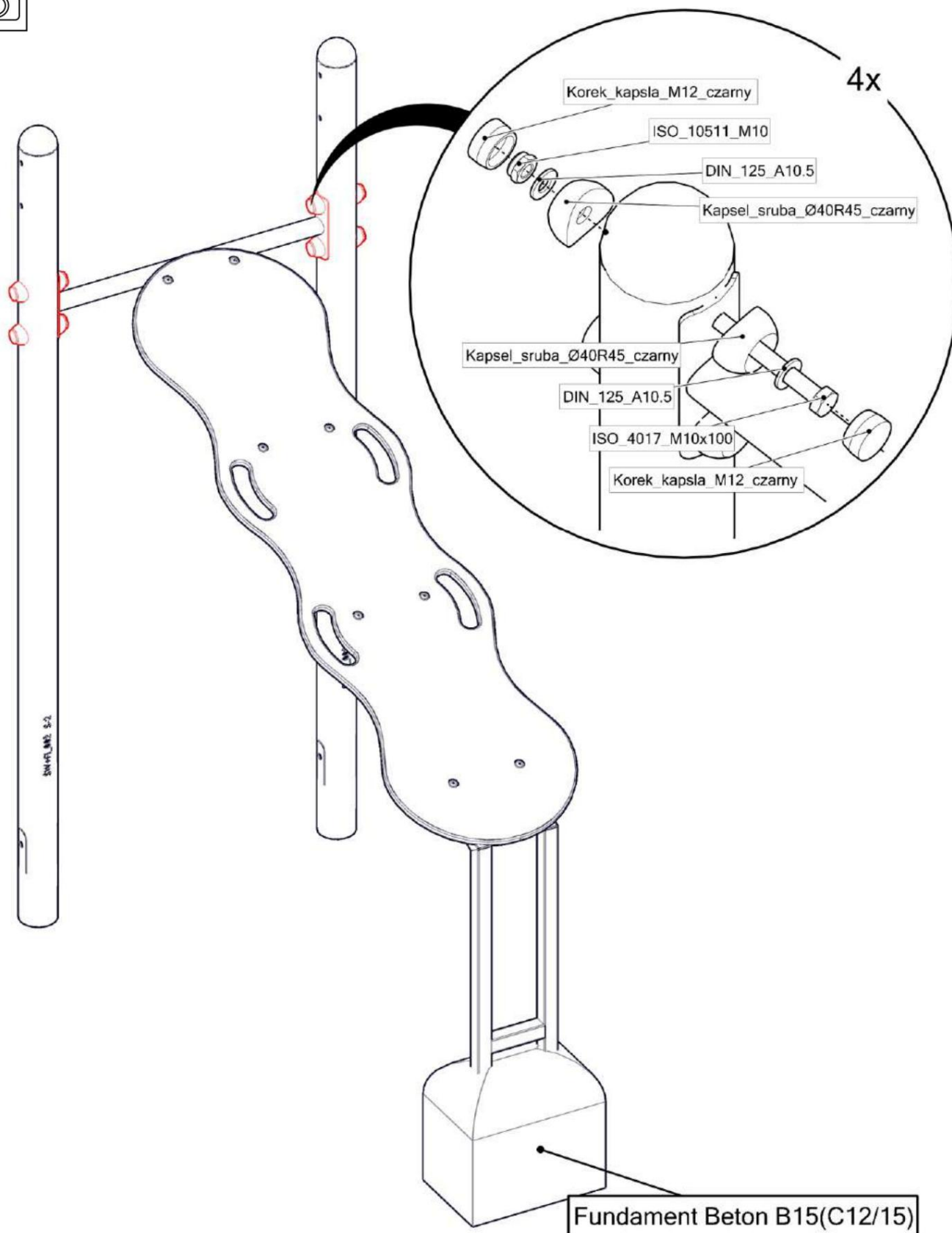

ALL STAGES OF FOUNDATION AND ASSEMBLY MUST BE PHOTOGRAPHICALLY DOCUMENTED.
THE LACK OF PHOTOGRAPHIC DOCUMENTATION WILL AFFECT THE ISSUANCE OF THE WARRANTY CARD.



INSTALLATION OF FOOT PRESS/TWISTER/BIKE EQUIPMENT

FI-005, FI-013, FI-015

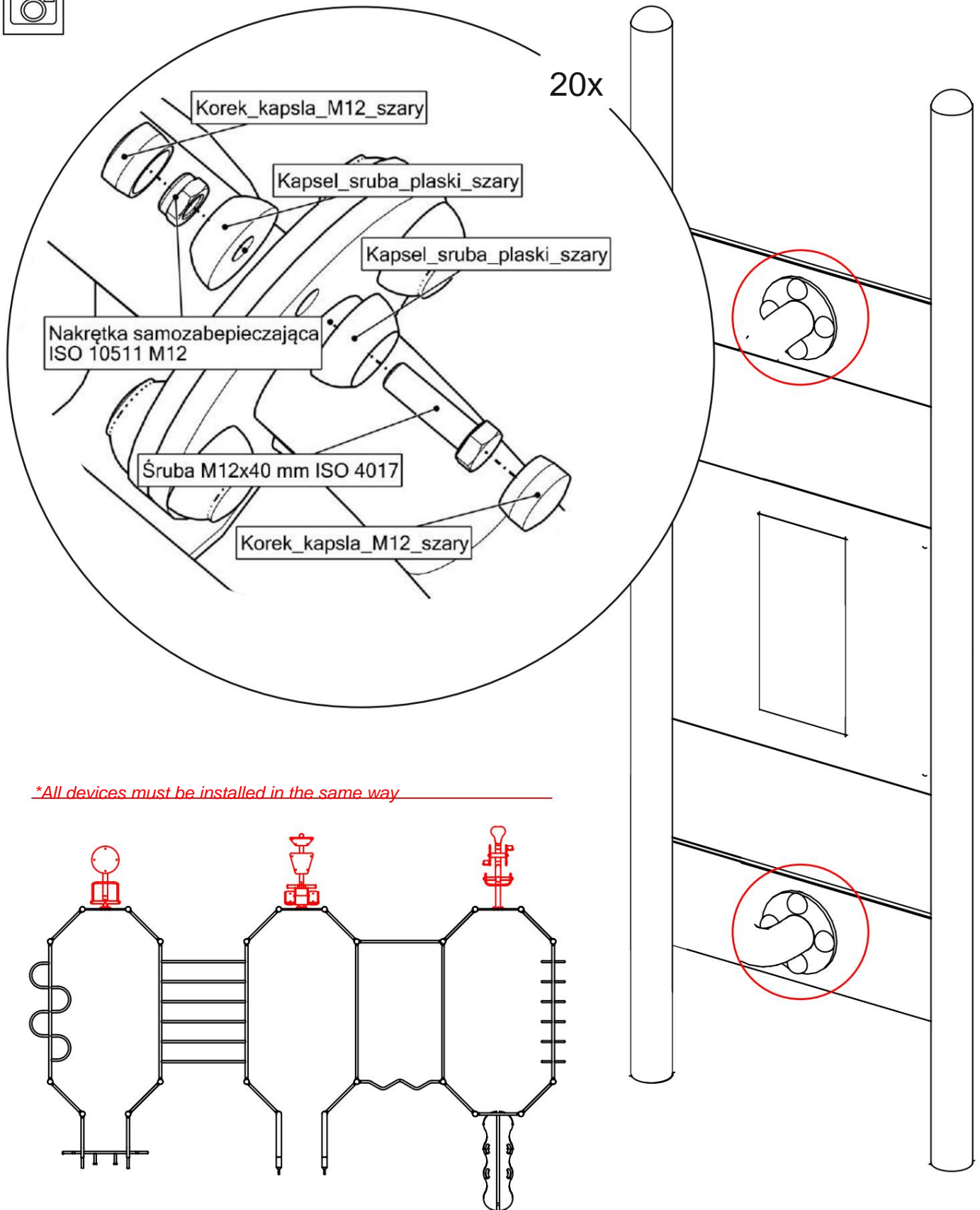

**All devices must be installed in the same way*

ALL STAGES OF FOUNDATION AND ASSEMBLY MUST BE PHOTOGRAPHICALLY DOCUMENTED.
THE LACK OF PHOTOGRAPHIC DOCUMENTATION WILL AFFECT THE ISSUANCE OF THE WARRANTY CARD.



SIMBA[®]
Group

INSTALLATION OF PARALLEL GYMNASTIC RINGS

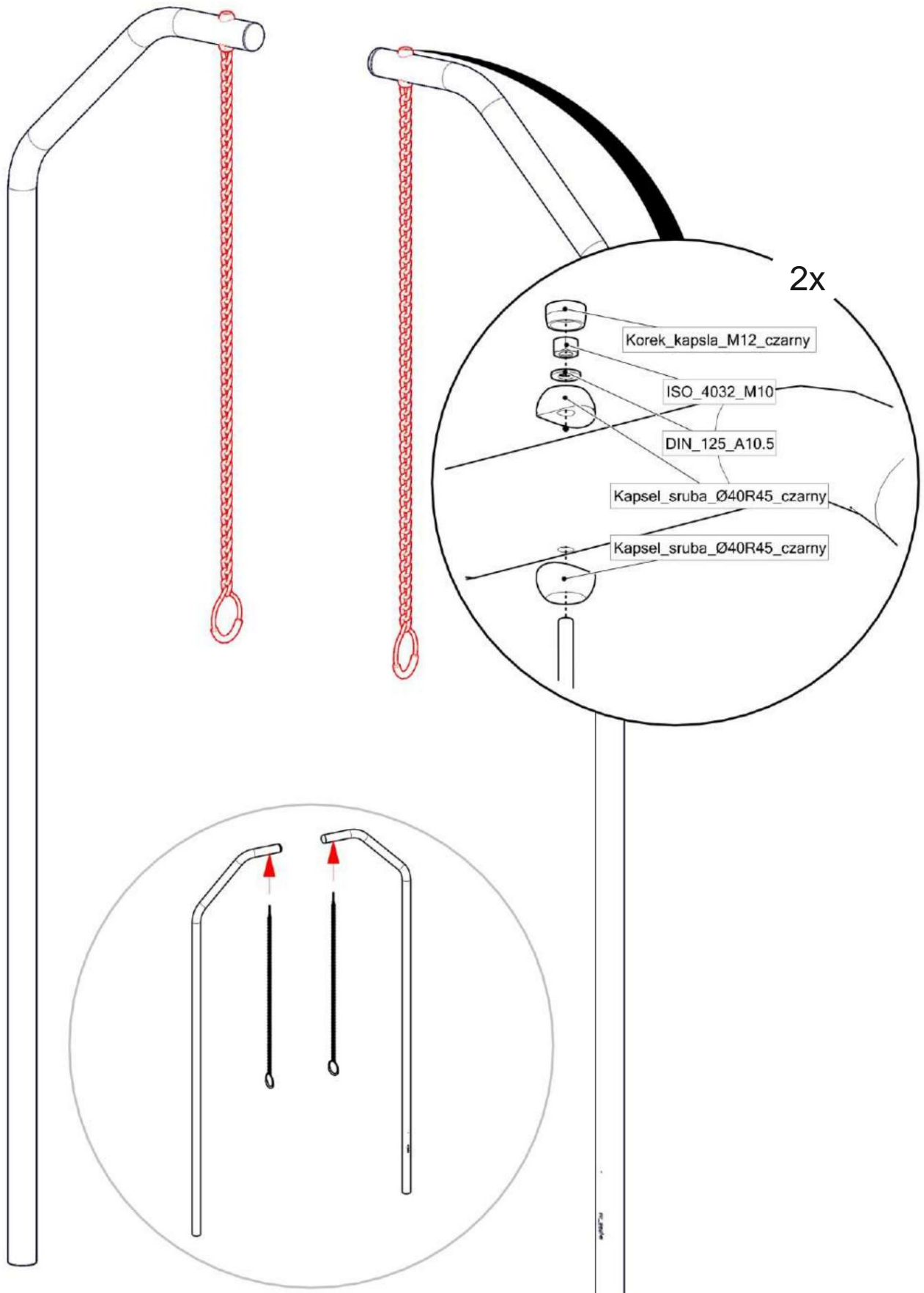

ALL STAGES OF FOUNDATION AND ASSEMBLY MUST BE PHOTOGRAPHICALLY DOCUMENTED.
THE LACK OF PHOTOGRAPHIC DOCUMENTATION WILL AFFECT THE ISSUANCE OF THE WARRANTY CARD.



SIMBA[®]
Group

STREET FITNESS SW+FI-008

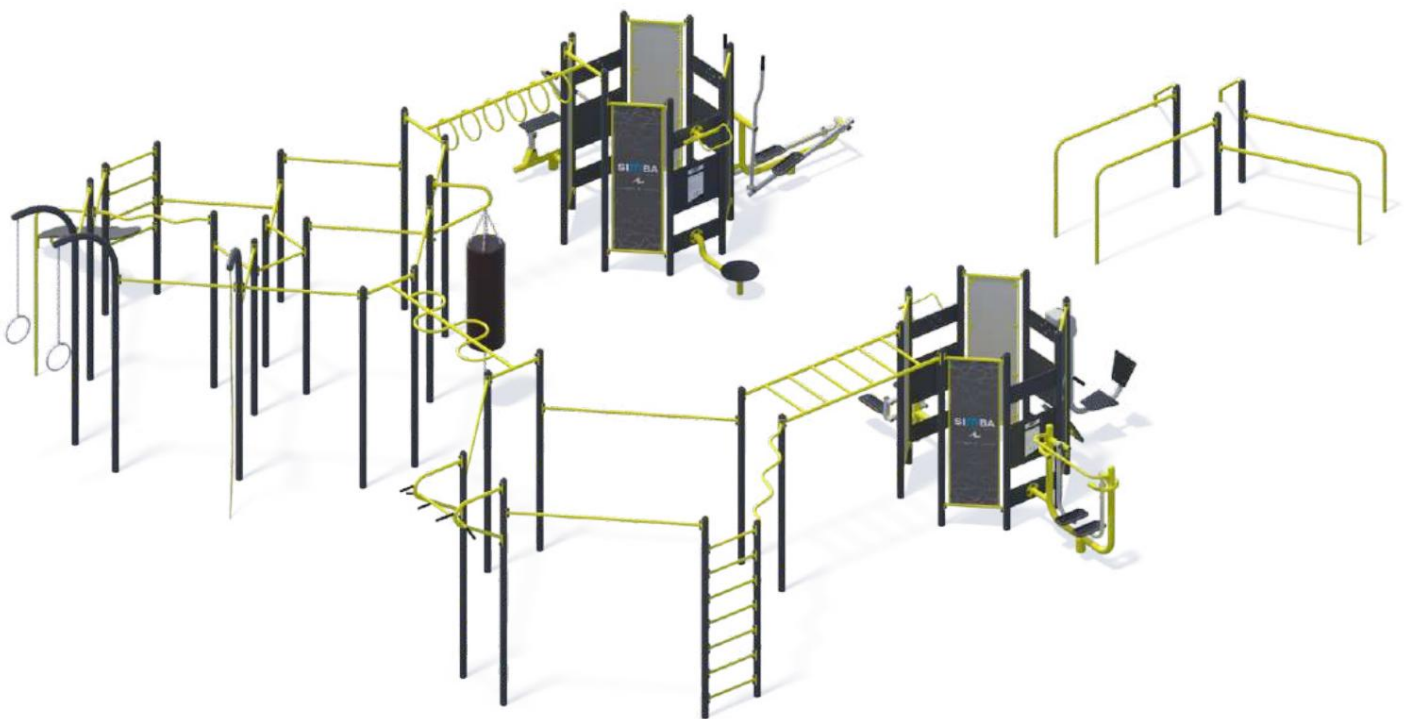

2026

ALL STAGES OF FOUNDATION AND ASSEMBLY MUST BE PHOTOGRAPHICALLY DOCUMENTED.
THE LACK OF PHOTOGRAPHIC DOCUMENTATION WILL AFFECT THE ISSUANCE OF THE WARRANTY CARD.



Examples of standard impact-absorbing materials, their thicknesses and their corresponding maximum free fall heights (**according to EN 1176-1:2017**)

MATERIAL ^a	DESCRIPTION	THICKNESS MINIMUM ^b	MAXIMUM HEIGHT FREE FALL
If the completed surface is verified (e.g. sieve test) in accordance with this Table or has a test report in accordance with EN 1177 , no further tests are necessary.	mm	mm	mm
TURF / SOIL	-	-	less than or equal to 1,000 ^d
BARK	grain size from 20 to 80	200	less than or equal to 2,000
		300	less than or equal to 3,000
WOOD CHIPS	grain size from 5 to 30	200	less than or equal to 2,000
		300	less than or equal to 3,000
SAND OR GRAVEL ^c	grain size from 0.25 to 8	200	less than or equal to 2,000
		300	less than or equal to 3,000
OTHER MATERIALS AND OTHER THICKNESSES	According to EN 1177 testing		Critical fall height according to the study

^a For further information on specific materials suitable for use on playgrounds children's play areas see CEN/TR 16598 (Collection of justifications for the requirements of EN 1176-1)

^b For bulk material, add 100mm to the minimum depth to compensate for displacement (see 4.2.8.5.1)

^c Sand and gravel should be well rounded and washed to eliminate most silt or clay particles. Washed sand or gravel is considered to be from alluvial (naturally eroded) deposits and free from most silt or clay particles. Gravel may be commonly referred to as "cobble." The uniformity coefficient D60/D10 <3.0. Particle size can be determined using a sieve test according to EN 933-1 (see Annex G).

^d See NOTE2 in 4.2.8.5.2.

INSTALLATION / ASSEMBLY

ÿ Installation only in a place ensuring a minimum free area - the so-called impact surface; ÿ Installation of the device in accordance with the design documentation while maintaining the following conditions;

ÿ The distance of the device from windows of rooms intended for human occupancy, from roads and places intended for waste collection should be at least 10 meters;

ÿ Distance from the playground to parking spaces: a) 7 m for up to 4 spaces inclusive, b) 10m in the case of 5 to 60 stations inclusive, c) 20m in the case of more than 60 stations, ÿ Installation

in an undeveloped area; ÿ Installation outside the safety zone of existing devices;

Particular attention should be paid to: - vertical positioning of the posts, - horizontal positioning of the bars and crossbars; -tightening screws and other fasteners;

INSTRUCTIONS FOR INSPECTION AND MAINTENANCE OF THE DEVICE

INSPECTION AND MAINTENANCE INSTRUCTIONS FOR RESPONSIBLE PERSONS FOR SAFETY IN THE RECREATIONAL AND SPORTS AREA

Daily inspection of the area, during which attention should be paid to: ÿ cleanliness of the area (all rubbish and items not belonging to the equipment of the square should be removed

playgrounds); ÿ clearances between the device and the ground; ÿ condition of the ground surface; ÿ shifted foundations; ÿ finishing of smoothed surfaces; ÿ missing and broken parts; ÿ condition of individual element connections.

Weekly inspection: ÿ

checking the condition of screw connections - tighten if loose; ÿ checking the condition of wooden surfaces - remove splinters if damaged.

Monthly inspection should include: ÿ checking

the functionality and stability of the device, tightening the screw connections if necessary occur;

ÿ supplementing the loose materials filling the area of the fall surface up to the base level mark placed on the device.

The inspection carried out at least once a year should include: ÿ inspection

of the technical condition and technical tests by the manufacturer's representative as part of concluded contract;

ÿ supplementing and levelling of soil and grass surfaces in the most exposed and intensively used areas; ÿ after each inspection, any irregularities found should

be immediately rectified or the use of faulty equipment should be prevented from being used until it is repaired; ÿ records of all actions taken as part of safety supervision should be kept in the equipment inspection and control book.

NOTE: The annual main inspection may require the unearthing or disassembly of parts of the unit.

REPLACEMENT OF WORN OR DAMAGED COMPONENTS

ÿ Metal parts of the device, connecting elements, and other components of the device are subject to replacement. If damage is detected, the following should be done: ÿ Secure the device from users until it is removed by fencing it.

ÿ construction warning tape with a suspended board informing about the damage; ÿ dismantle the damaged part of the device that poses a risk to playing children, e.g.: exposed parts of metal connectors, etc. ÿ during repairs, replace damaged or worn parts with identical ones supplied by the product manufacturer; ÿ if necessary, contact the device manufacturer's service center.

INSTRUCTIONS FOR INSPECTION AND MAINTENANCE OF THE DEVICE

In the area where the devices are installed, a board should be placed containing: ÿ the regulations for using the device; ÿ the telephone numbers of the fire brigade (998), ambulance service (999), police (997), site supervisor and the emergency number 112; ÿ all entrances and passages intended for users of the area and emergency services. must be constantly available, free from any obstacles.

INSTRUCTIONS - DEADLINE TESTING

After the device is installed, jam tests should be performed to verify correct installation. All tests should be performed under the most unfavorable conditions.

Instructions prepared on the basis of the **EN 1176 1:2017** standard (Part 1: General safety requirements and test methods).

- 1** Perform **head and neck** entrapment testing using probes/templates in fully enclosed, partially enclosed and V-shaped openings according to procedure **D.2.1.2** and **D.2.2.2**.
- 2** Perform a **clothing** entrapment test using a testing device/button/chain in accordance with procedure **D. 3.2.** on tested devices such as: slides, fireman's poles, canopies.
- 3** Perform a **finger** pinch test using the finger probe according to procedure **D.4.2**.
- 4** Test **the chain holes** using a chain tester according to procedure **D.5.2**.
- 5** Perform an examination/measurement of devices that may cause **whole body** entrapment based on point **4.2.7.4**.
- 6** Perform an examination/measurement of gaps that may cause **foot or leg** entrapment based on point **4.2.7.5**.

A review of possible pinch situations should be carried out based on Table **E.1** (Annex E of EN 1176-1:2017) _____

FOUNDATION STAGES

1 PREPARING THE SUBSTRATE FOR THE DEVICE TO BE MOUNTED

1.1. Based on the foundation dimensions (provided in the instructions), dig a foundation trench to the appropriate width and depth.

1.2. The bottom of the trench should be leveled and compacted (it should form a stable base for the foundations).

2 PLACING THE DEVICE IN THE TRACKS AND INSTALLING IT

2.1. The device poles must be placed in excavations.

2.2. Assembling the entire set (aligning the verticals and horizontals using a spirit level).

2.3. The poles placed in the trench are poured with a previously prepared concrete mixture (concrete class minimum C12/15).

3 PROTECTING THE DEVICE AGAINST USE

3.1. The device must be secured against use until the foundations have set (their appropriate strength parameters have been achieved).

3.2. After the concrete has set, the excavations should be backfilled with a layer of soil to the ground level in accordance with the documentation (the ground level should be marked on the posts).

3.3. Once the device is fully assembled and stabilized, remove the safety device.

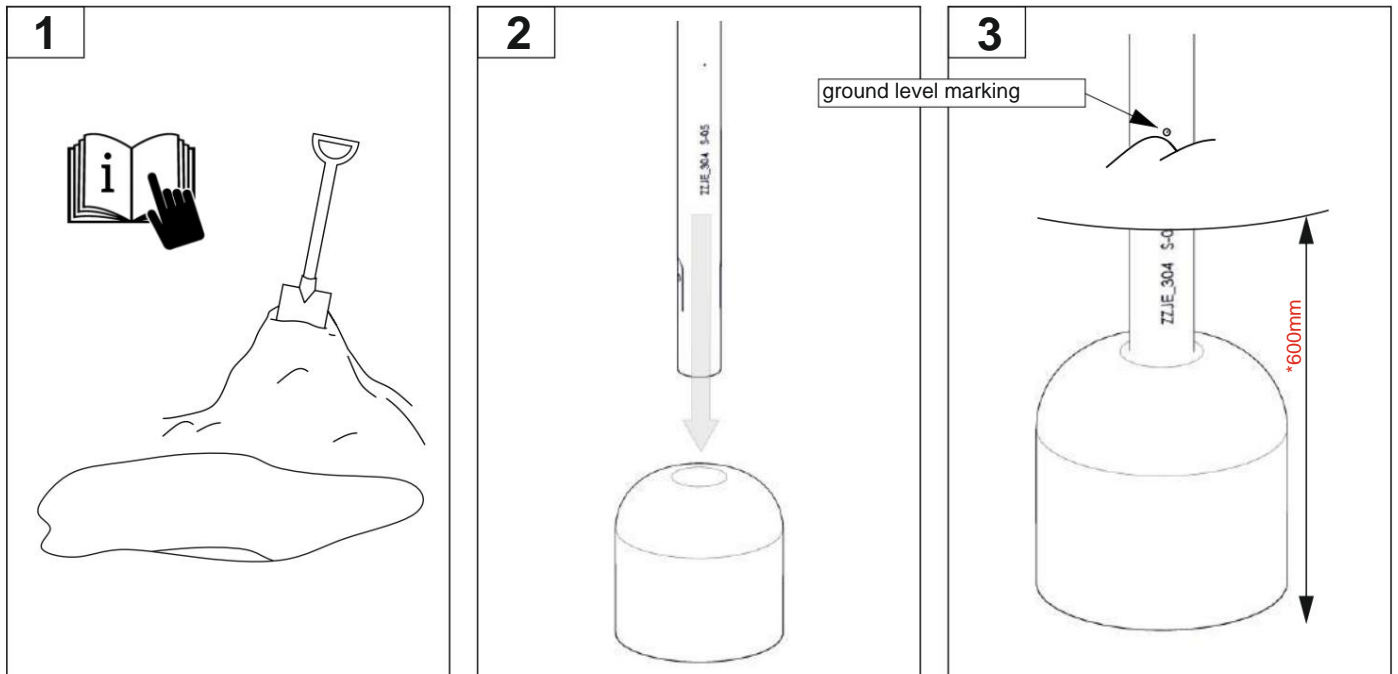

*the depth of the excavation and foundation should be made according to the basic foundation (individual foundations included in the instructions)

ALL STAGES OF FOUNDATION AND ASSEMBLY MUST BE PHOTOGRAPHICALLY DOCUMENTED.

THE LACK OF PHOTOGRAPHIC DOCUMENTATION WILL AFFECT THE ISSUANCE OF THE WARRANTY CARD.

BASIC FOUNDATION

FOUNDATION SHAPES

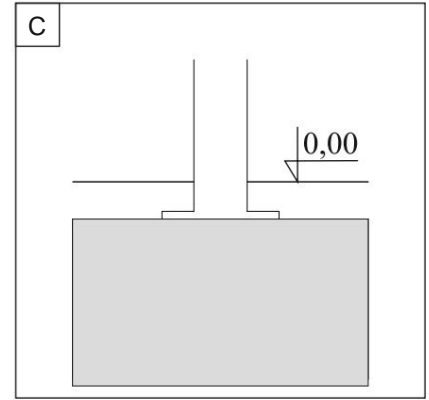
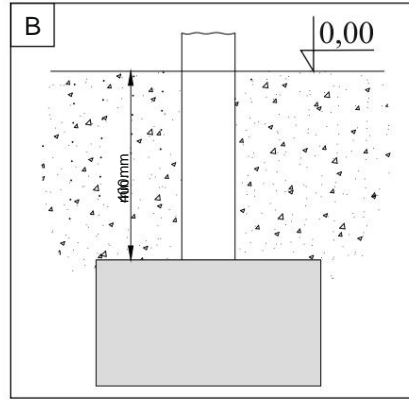
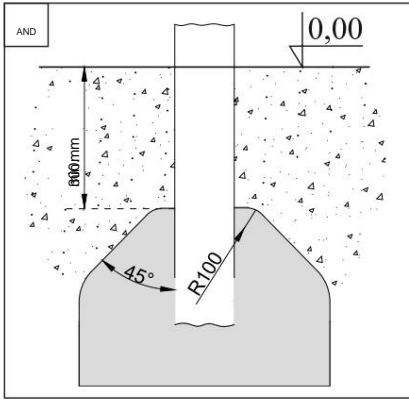

A The **FOUNDATION** has R100 roundings - the minimum distance is **300 mm** below the ground;

B The **FOUNDATION** has no roundings, the minimum distance is **400 mm** (for loose surfaces: sand, gravel, etc.); **C** **FOUNDATION**

with a foundation slab (safe surface - SBR).

MEASUREMENT OF FOUNDATIONS IN PLAYGROUNDS AND OUTDOOR GYMS

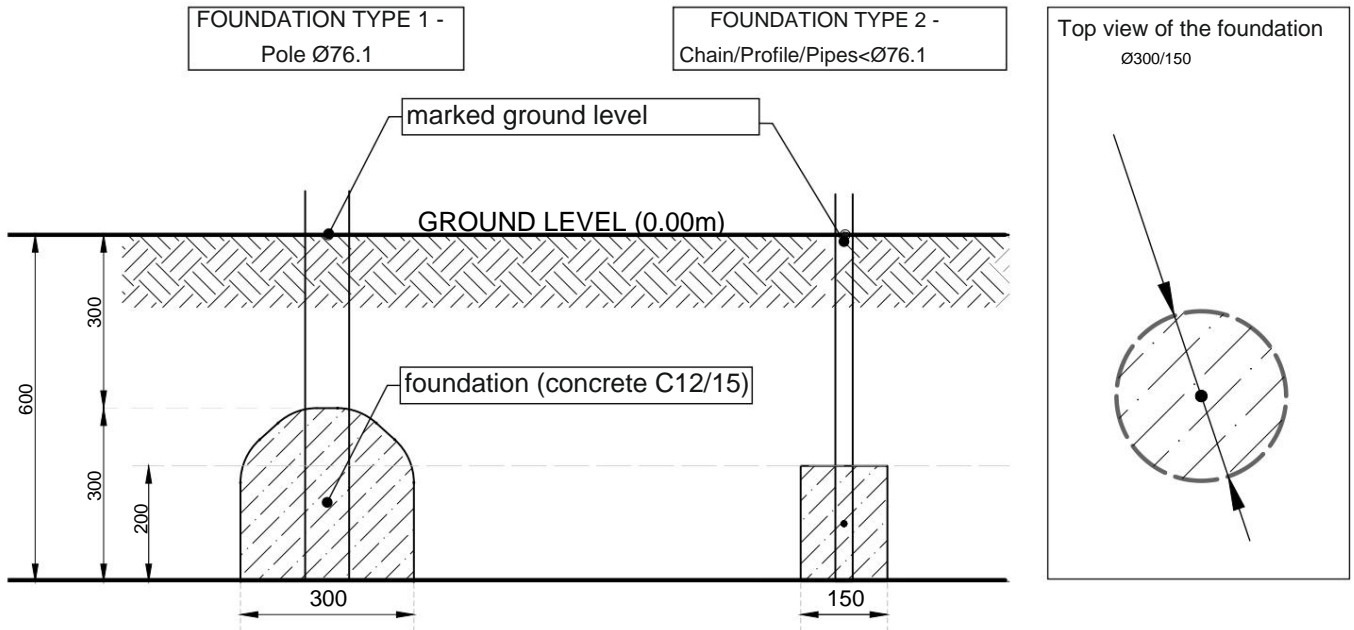

**Foundation in a trough (the basic foundation dimensions are increased by 300mm)*

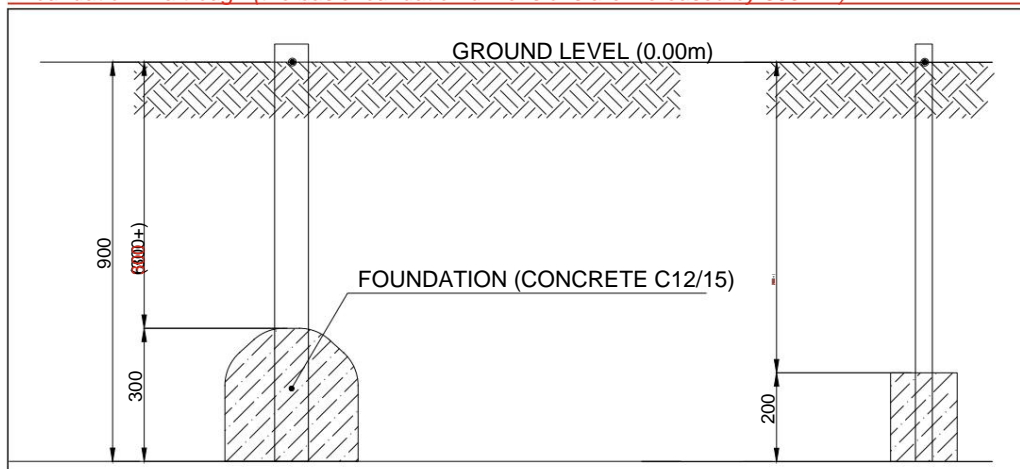

NOTE! Foundations for columns larger than 76.1 mm should be carried out according to individual instructions or technical documentation.

*Dimensions given in units [mm]

SIMBA[®]
Group

FALL SPACE RANGE

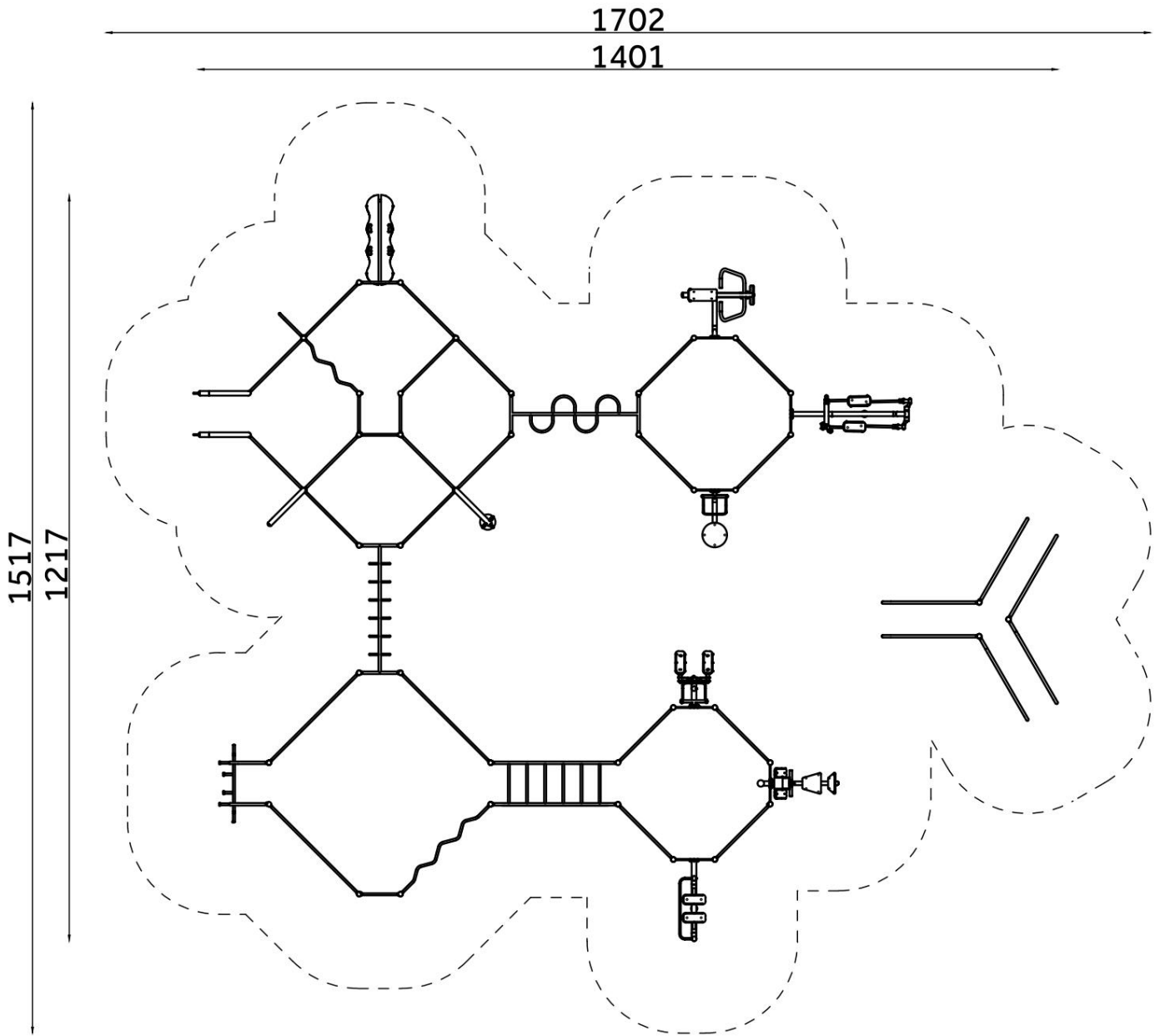

DEVICE ARRANGEMENT

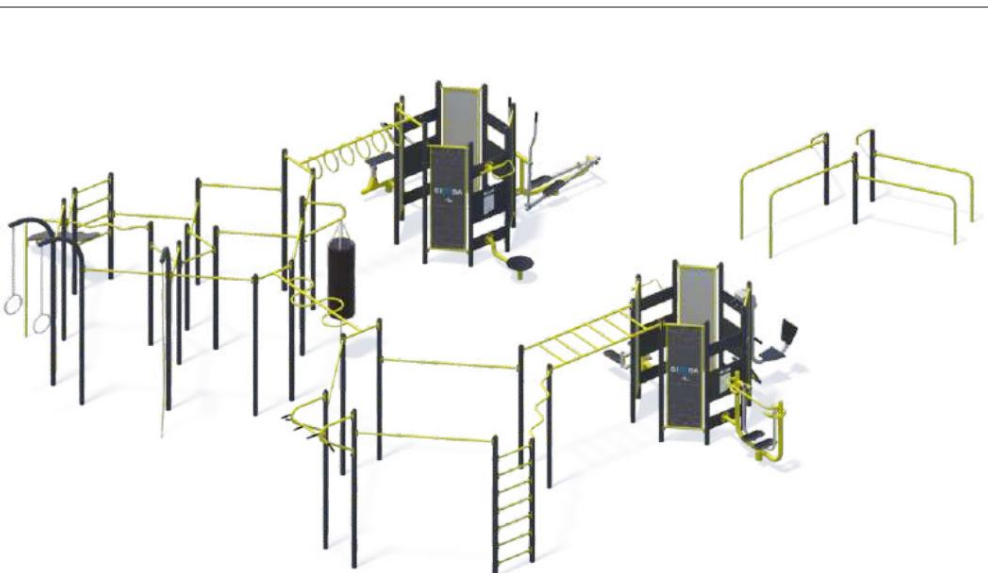
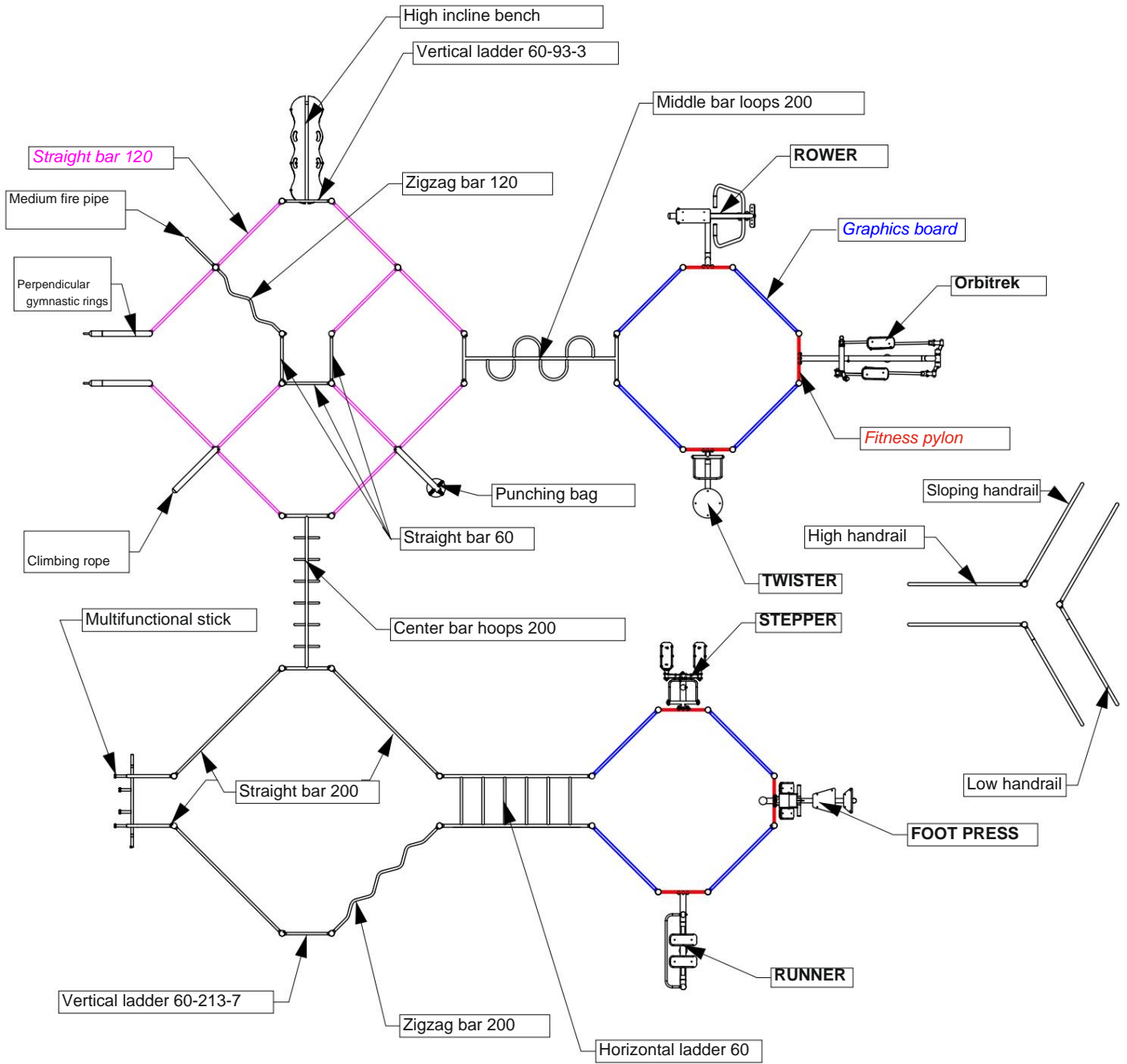

LIST OF SET COMPONENTS

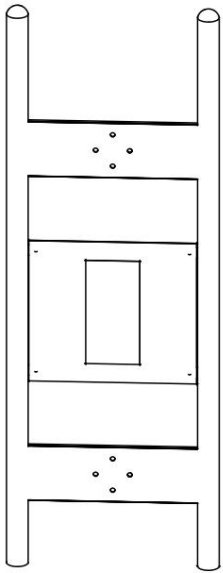

SW-050
Fitness pylon 6 pcs.

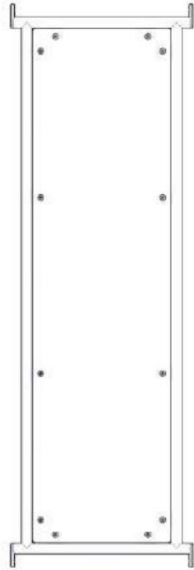

SW-052
Graphics board
8 pcs.

SW-042
Medium fire pipe 1
pc.

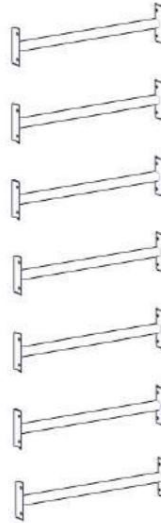
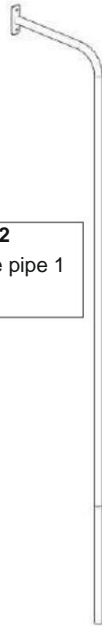

SW-014-7
Vertical ladder 60-213-7
1 pc.

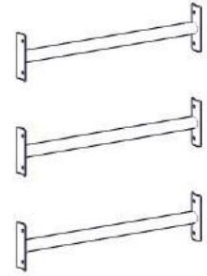

SW-014-3
Vertical ladder 60-93-3 1 pc.



SW-029
Straight bar 60 3 pcs.

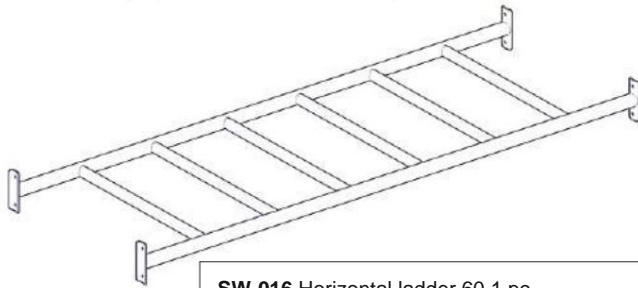

SW-016 Horizontal ladder 60 1 pc.

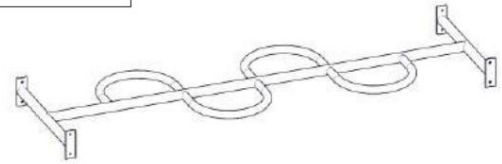

SW-021 Middle rod loops 200 1 pc.

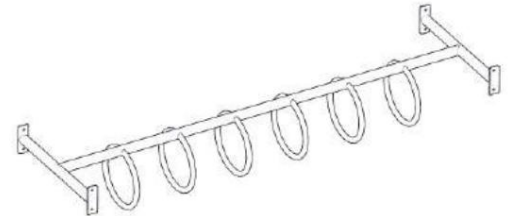

SW-024 Center bar hoops 200 1 pc.



SW-032
Perpendicular gymnastic
rings 1 pc.

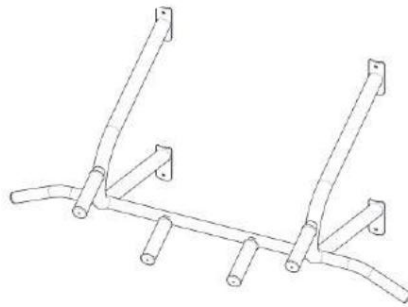

SW-026
Multifunctional stick 1 pc.



SW-027 Straight bar 200 3 pcs.



SW-028 Straight bar 120 11 pcs.

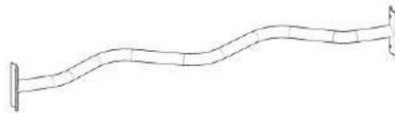

SW-031 Zigzag rod 120 1 pc.



SW-030 Zigzag bar 200 1 pc.

NOTE! Before assembly, check the number of individual components included in the kit.

NOTE! The number of mounting elements may not match the list (individual components of the set are assembled before shipping to the customer)

LIST OF SET COMPONENTS

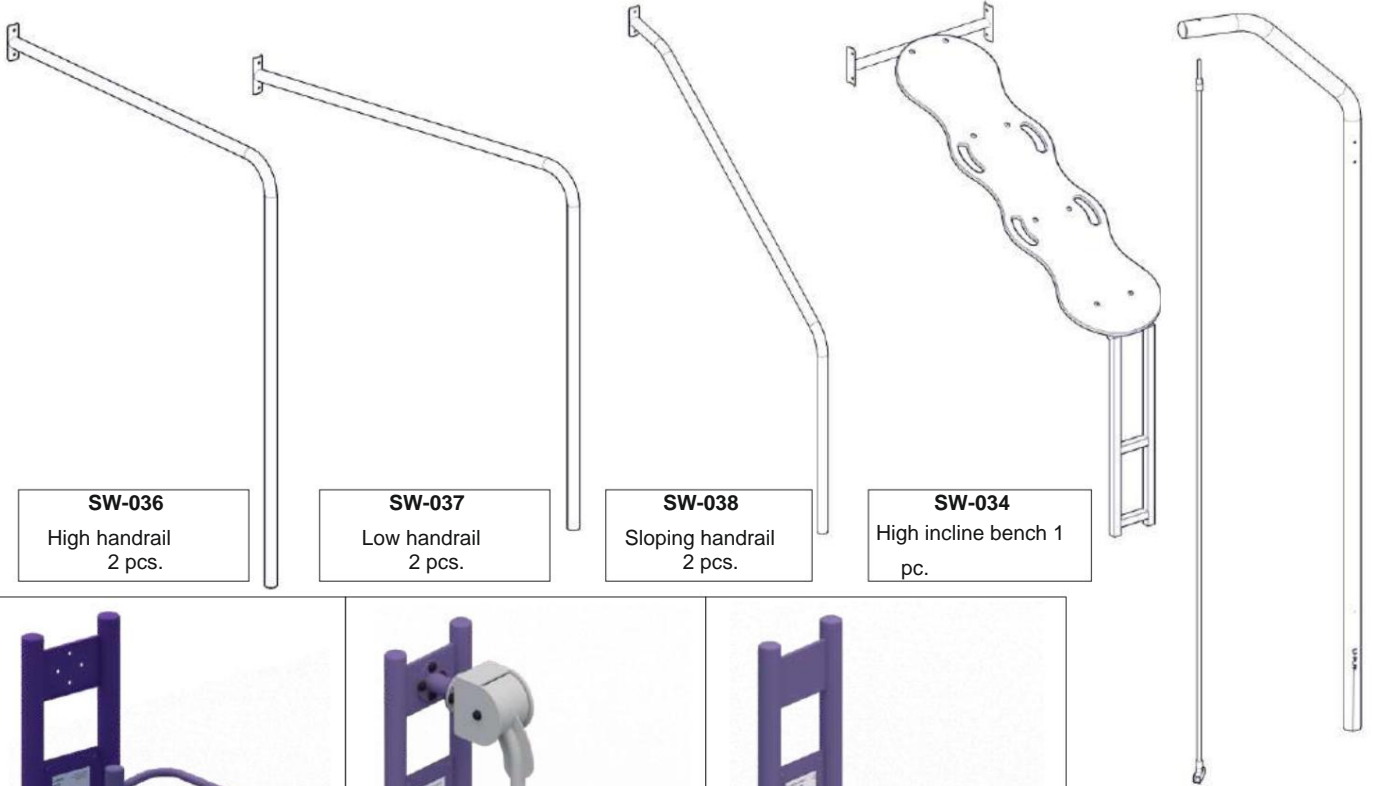

FI-001 Runner 1 pc.



FI-005 Foot press 1 pc.



FI-009 Rowing machine 1 pc.



FI-011 Stepper 1 pc.



FI-012 Elliptical trainer 1 pc.



FI-015 Twister 1 pc.

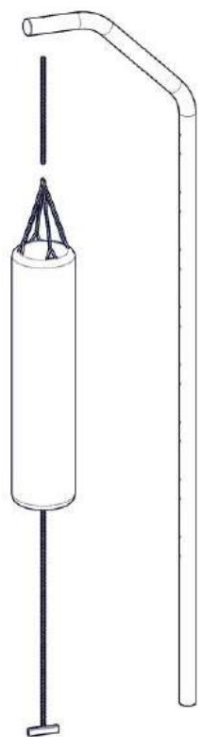









SW-045 Punching bag 1 pc.



NOTE! Before assembly, check the number of individual components included in the kit.

NOTE! The number of mounting elements may not match the list (individual components of the set are assembled before shipping to the customer)

LIST OF FASTENING ELEMENTS

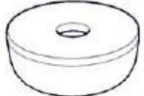
				
DIN 7380-2 M8x30 Allen screw with washer head	ISO 4017/DIN 933 M12x40 Hexagon head screw 40	ISO 4017/DIN 933 M10x100 Hexagon head screw	DIN 125 A10.5 Round flat washer	DIN 125 A13 Round flat washer
32 pcs.	pcs.	166 pcs.	332 pcs.	2 pcs.

				
ISO 10511 M10 Nut Hexagonal	ISO 10511 M12 self-locking nut self-locking	CAP CONCAVE M8	CAP CONCAVE M12	FLAT CAP M12
166 pcs.	42 pcs.	32 pcs.	336 pcs.	80 pcs.

		
CAP CAP M8	CAP CAP M12	STRAIGHT SHACKLE M8
32 pcs.	82 pcs.	1 pc.

NOTE! Before assembly, check the number of individual components included in the kit.

NOTE! The number of mounting elements may not match the list (individual components of the set are assembled before shipping to the customer)

INSTALLATION OF GRAPHIC BOARDS TO PYLONS AND POLE SW-052

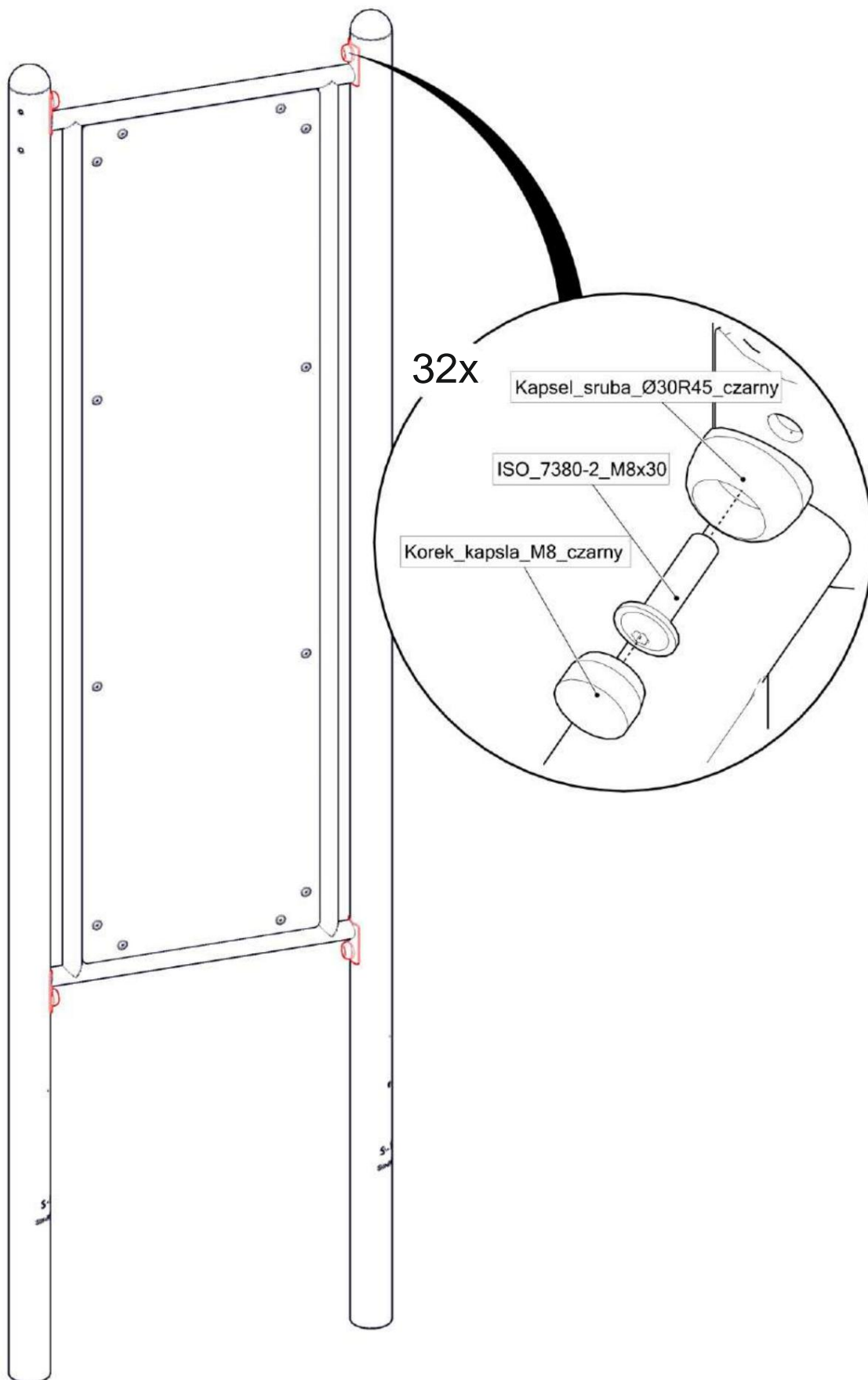

ALL STAGES OF FOUNDATION AND ASSEMBLY MUST BE PHOTOGRAPHICALLY DOCUMENTED.
THE LACK OF PHOTOGRAPHIC DOCUMENTATION WILL AFFECT THE ISSUANCE OF THE WARRANTY CARD.



SIMBA[®]
Group

INSTALLATION OF LOOPS/HOOPS/ZIGZAG/STRAIGHT BARS

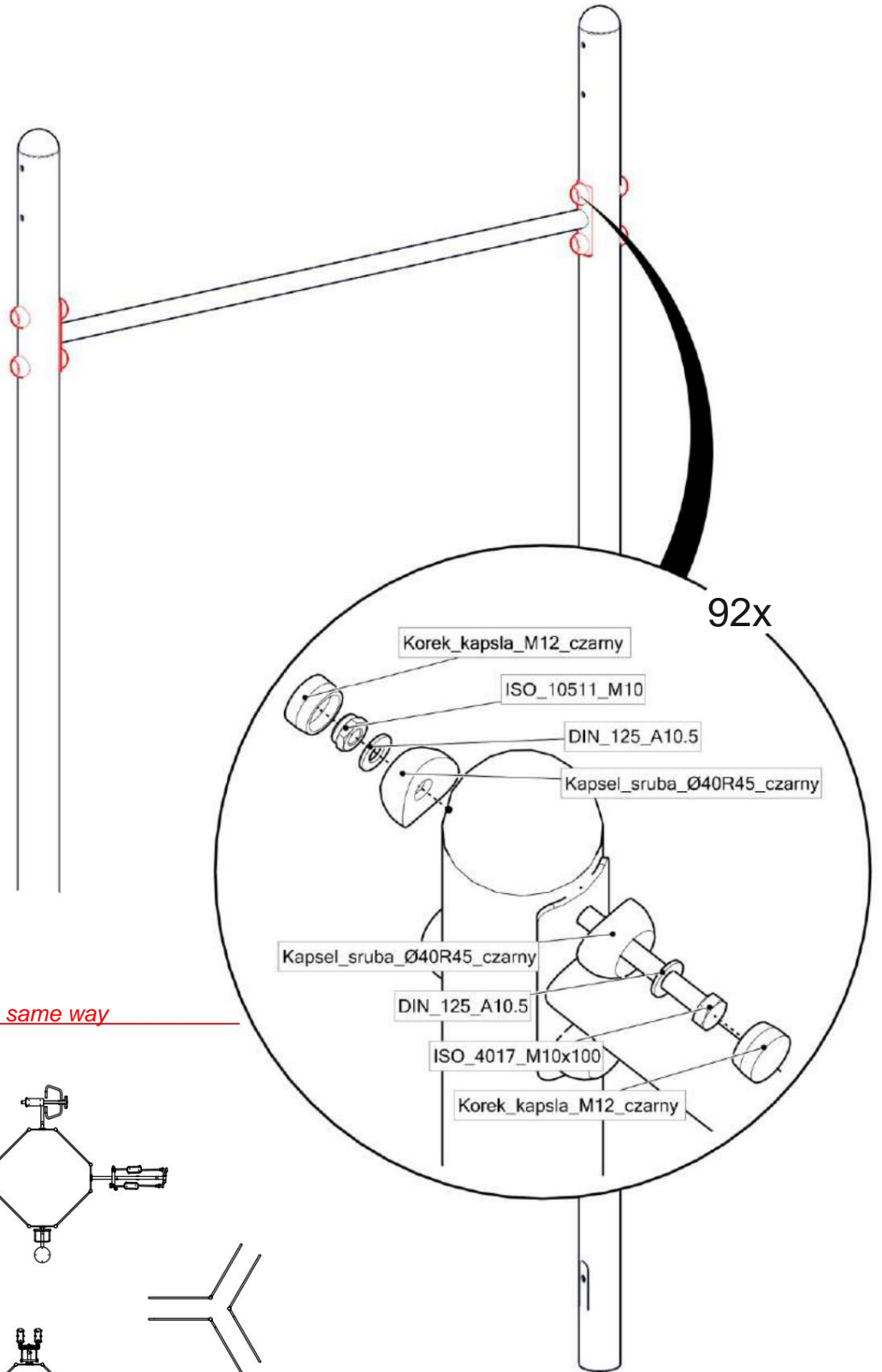

**All rods must be installed in the same way*

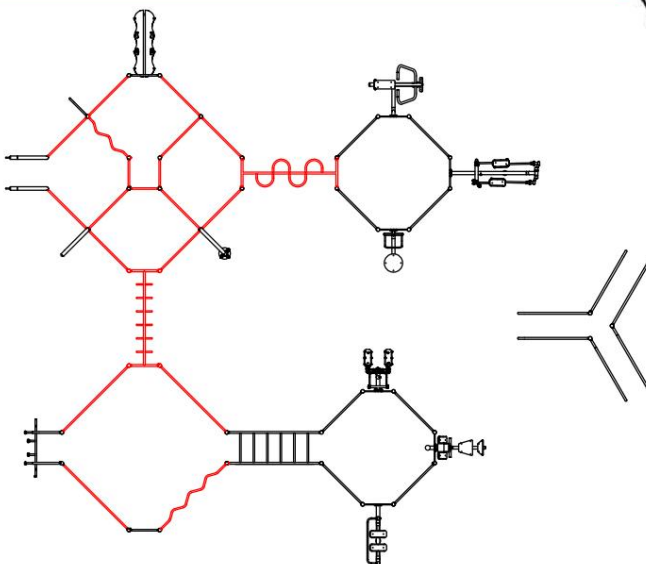

ALL STAGES OF FOUNDATION AND ASSEMBLY MUST BE PHOTOGRAPHICALLY DOCUMENTED.
THE LACK OF PHOTOGRAPHIC DOCUMENTATION WILL AFFECT THE ISSUANCE OF THE WARRANTY CARD.



INSTALLATION OF VERTICAL AND HORIZONTAL LADDERS

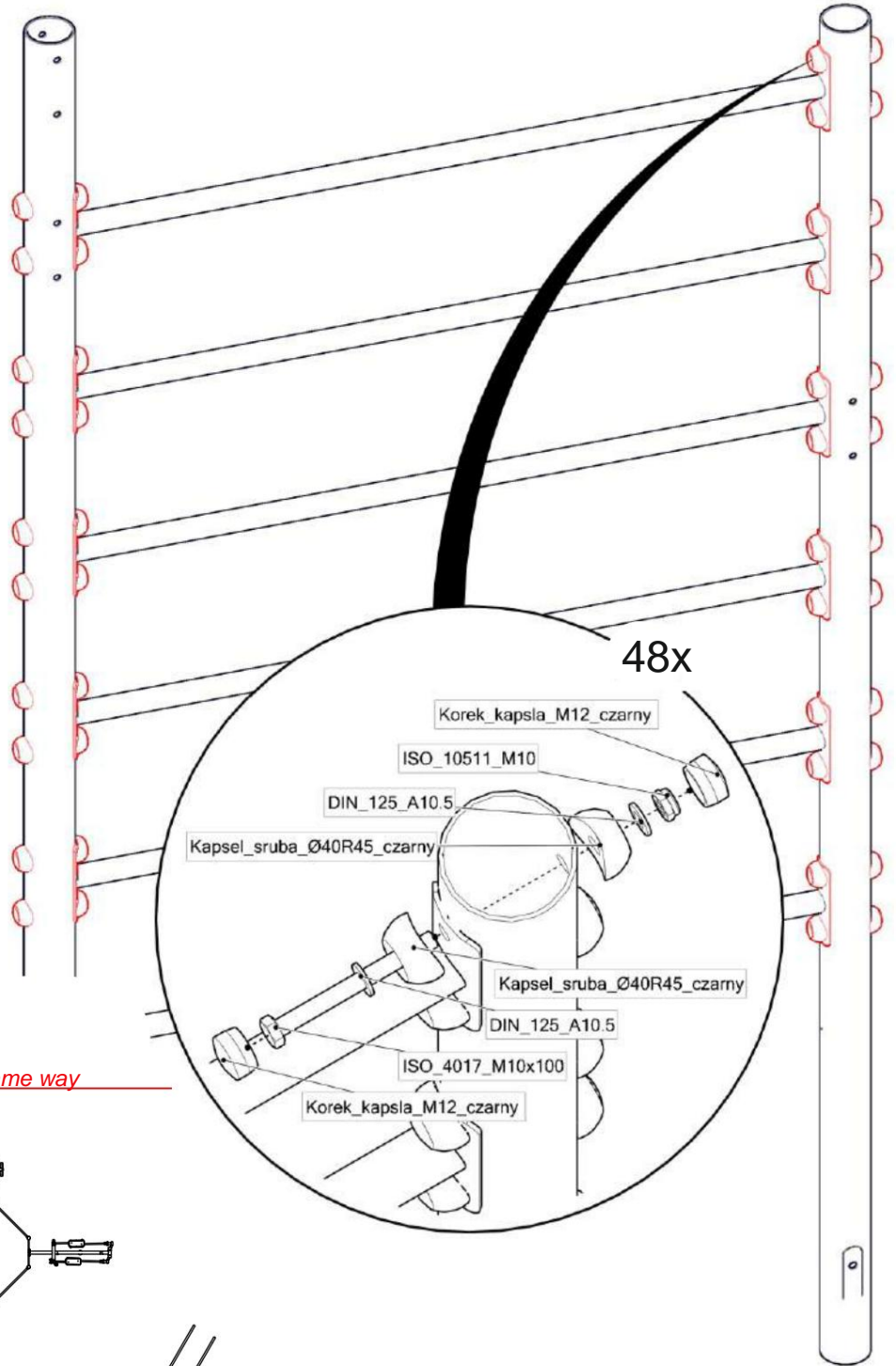

**All ladders must be assembled in the same way*

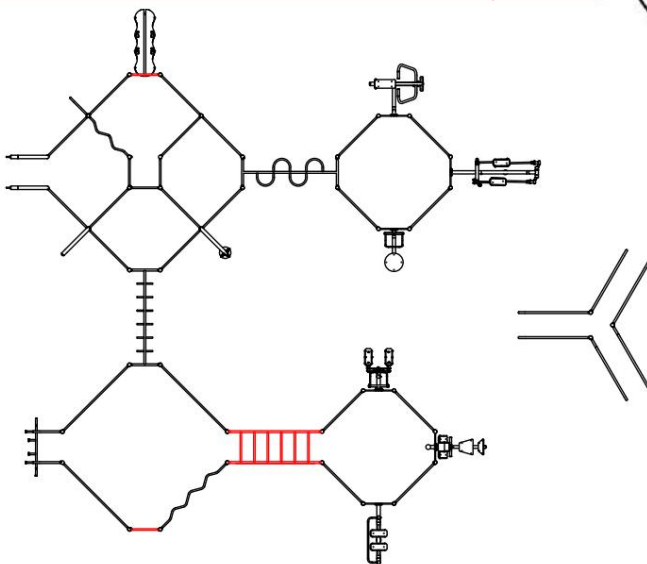

ALL STAGES OF FOUNDATION AND ASSEMBLY MUST BE PHOTOGRAPHICALLY DOCUMENTED.
THE LACK OF PHOTOGRAPHIC DOCUMENTATION WILL AFFECT THE ISSUANCE OF THE WARRANTY CARD.



SIMBA[®]
Group

INSTALLATION OF THE HIGH INCLINED BENCH SW-034

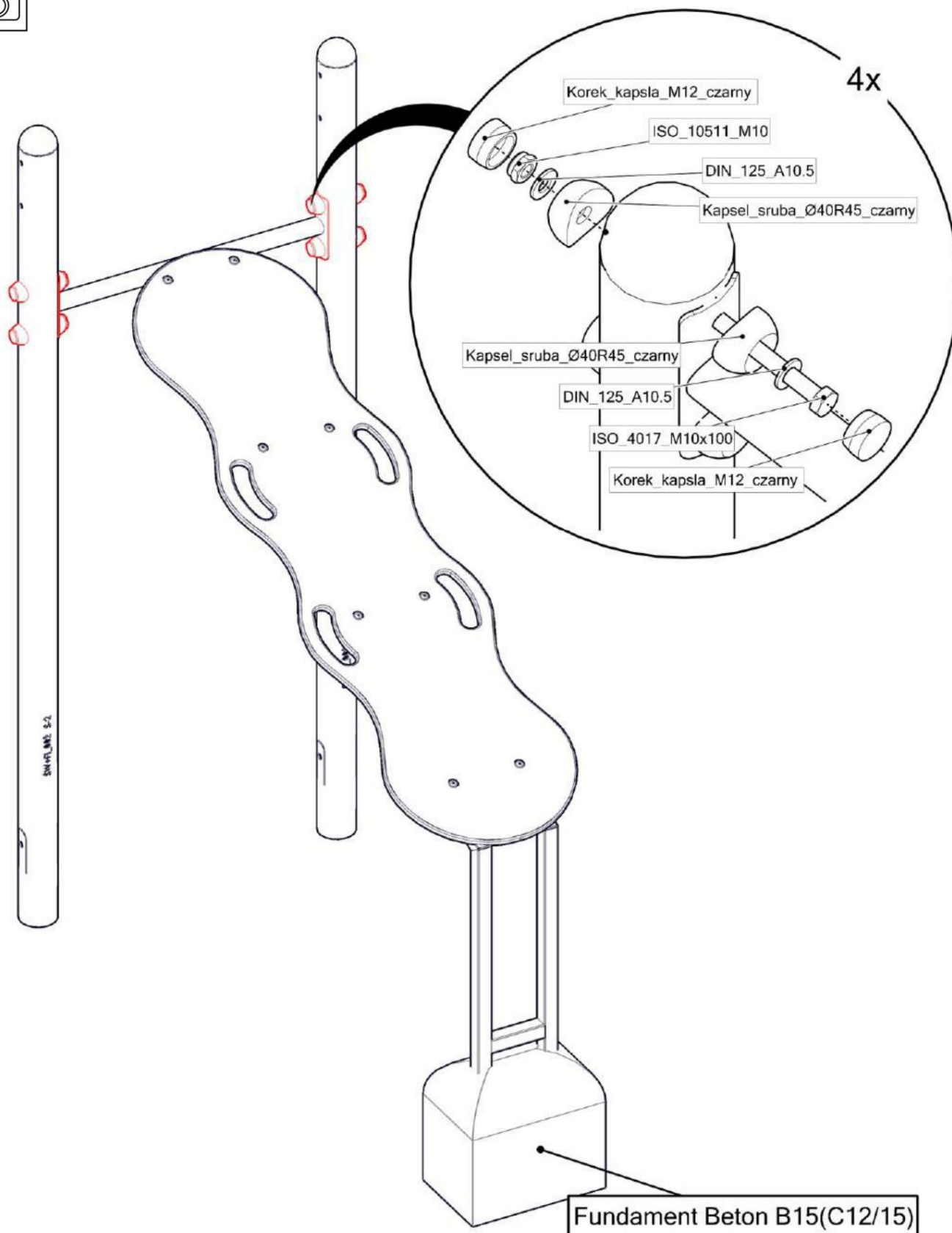

ALL STAGES OF FOUNDATION AND ASSEMBLY MUST BE PHOTOGRAPHICALLY DOCUMENTED.
THE LACK OF PHOTOGRAPHIC DOCUMENTATION WILL AFFECT THE ISSUANCE OF THE WARRANTY CARD.



INSTALLATION OF RUNNERS/STEPPER/ORBVITREK/TWISTER/LEG PRESS/ROWING MACHINES
 FI-001; FI-011; FI-012; FI-015; FI-005; FI-009

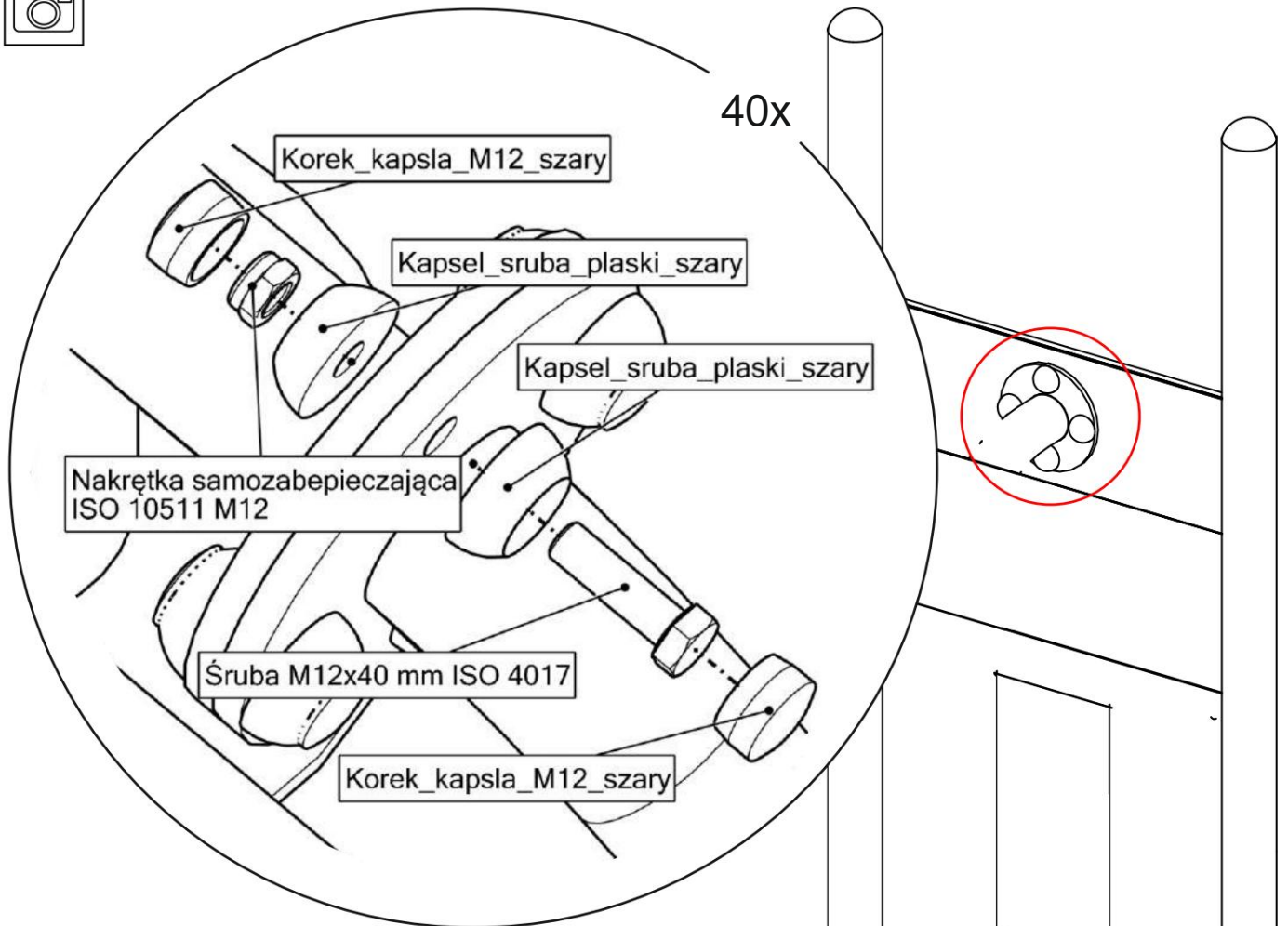

**All devices must be installed in the same way*

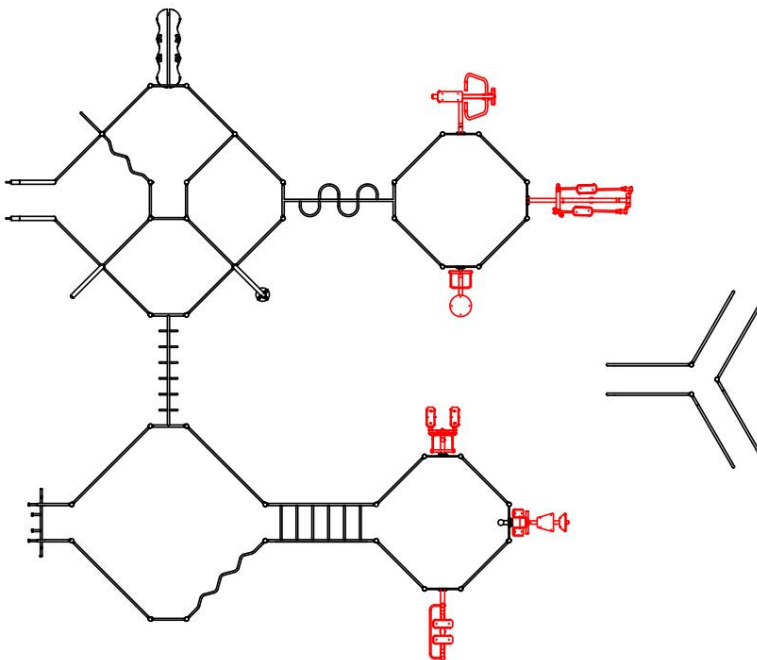

ALL STAGES OF FOUNDATION AND ASSEMBLY MUST BE PHOTOGRAPHICALLY DOCUMENTED.
 THE LACK OF PHOTOGRAPHIC DOCUMENTATION WILL AFFECT THE ISSUANCE OF THE WARRANTY CARD.



INSTALLATION OF HIGH/LOW/SCENTED HANDRAILS

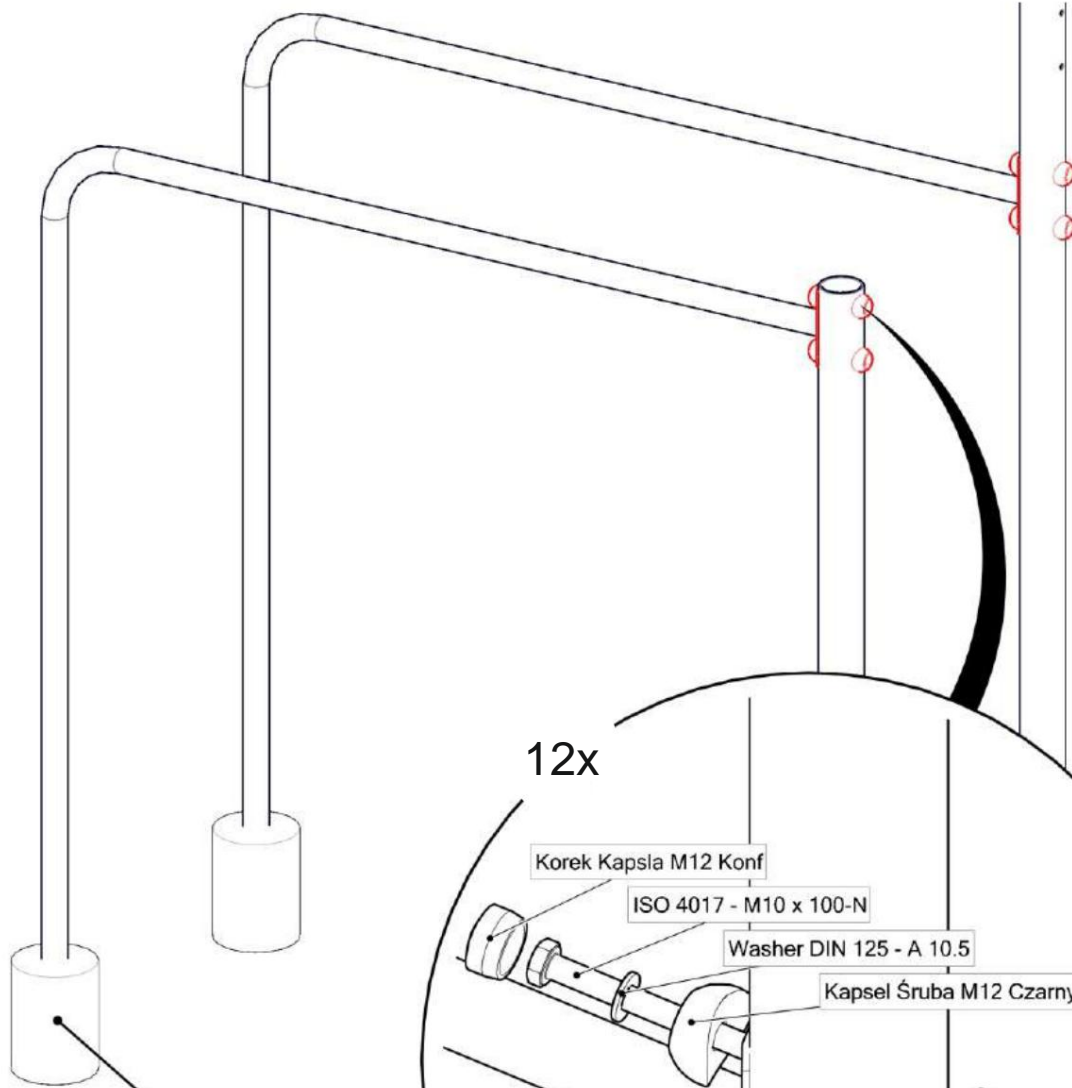

Fundament Beton Typ 2 B15(C12/15)

**All handrails must be installed in the same manner*

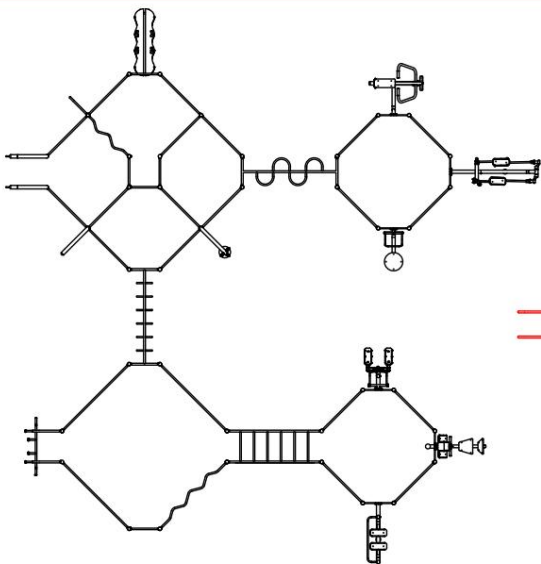

ALL STAGES OF FOUNDATION AND ASSEMBLY MUST BE PHOTOGRAPHICALLY DOCUMENTED.
THE LACK OF PHOTOGRAPHIC DOCUMENTATION WILL AFFECT THE ISSUANCE OF THE WARRANTY CARD.



INSTALLING THE MULTIFUNCTIONAL STICK

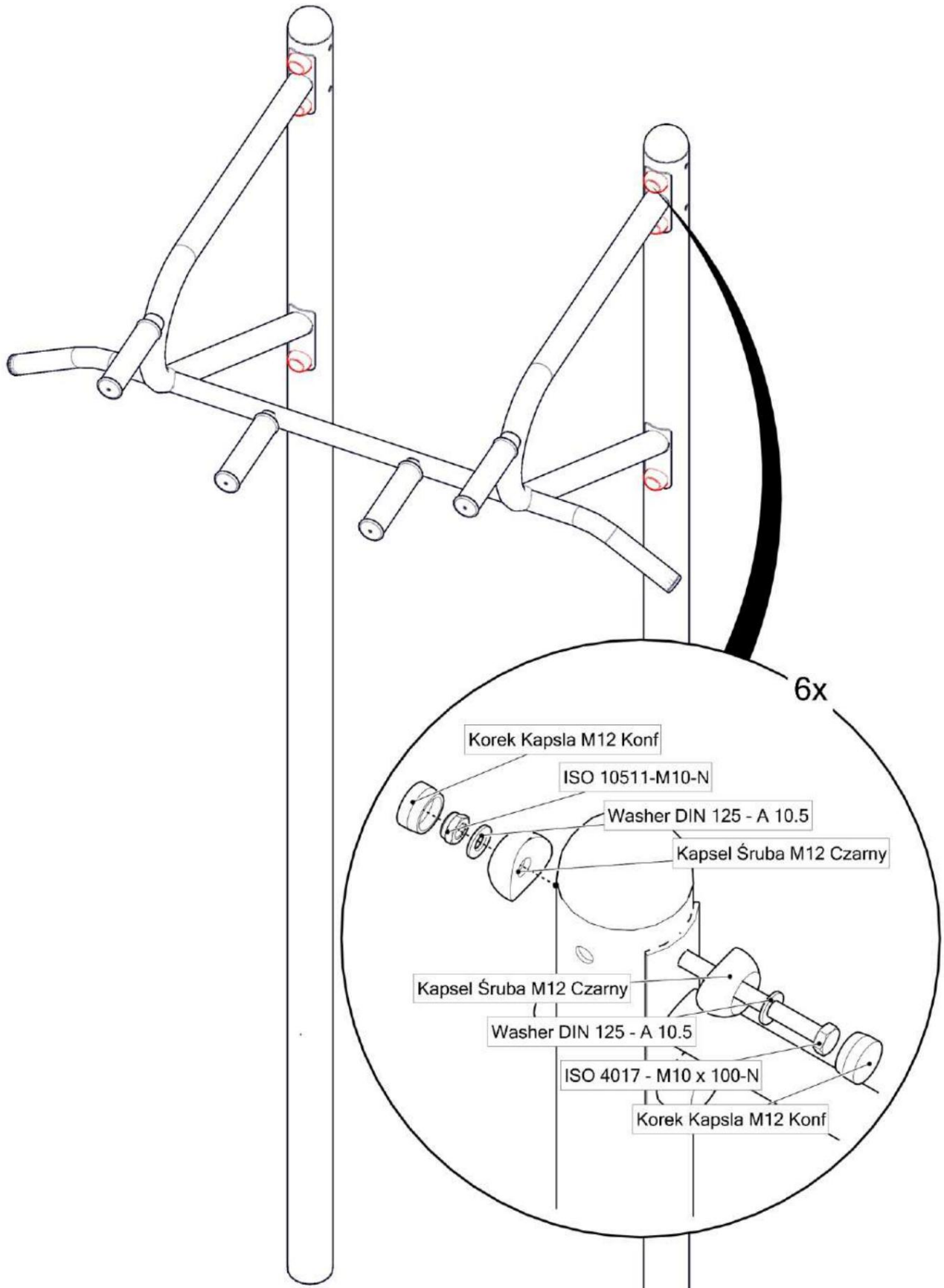

ALL STAGES OF FOUNDATION AND ASSEMBLY MUST BE PHOTOGRAPHICALLY DOCUMENTED.

THE LACK OF PHOTOGRAPHIC DOCUMENTATION WILL AFFECT THE ISSUANCE OF THE WARRANTY CARD.



SIMBA[®]
Group

INSTALLATION OF PERPENDICULAR GYMNASTIC RINGS

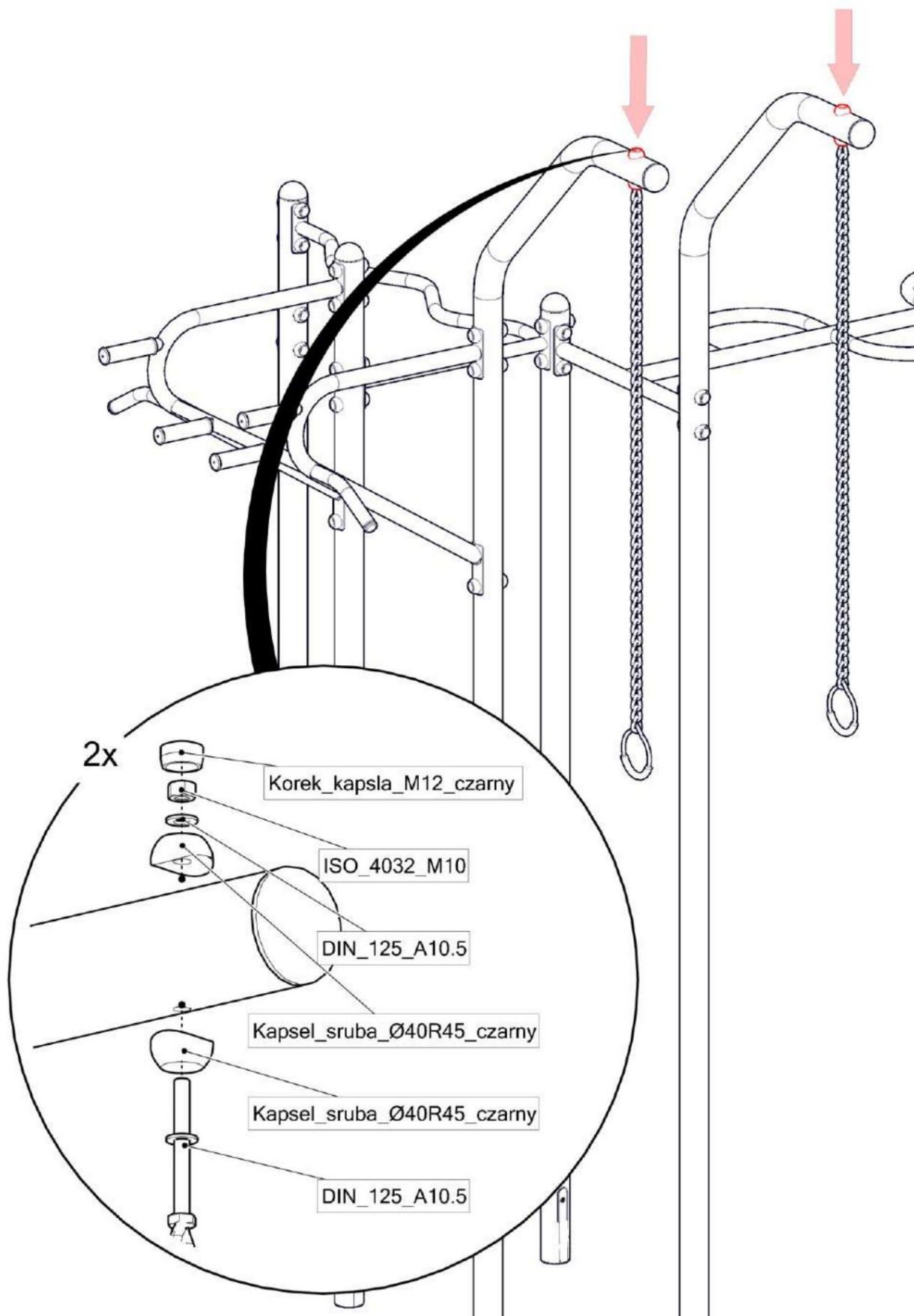

ALL STAGES OF FOUNDATION AND ASSEMBLY MUST BE PHOTOGRAPHICALLY DOCUMENTED.
THE LACK OF PHOTOGRAPHIC DOCUMENTATION WILL AFFECT THE ISSUANCE OF THE WARRANTY CARD.



SIMBA[®]
Group

INSTALLATION OF MEDIUM FIRE PIPE

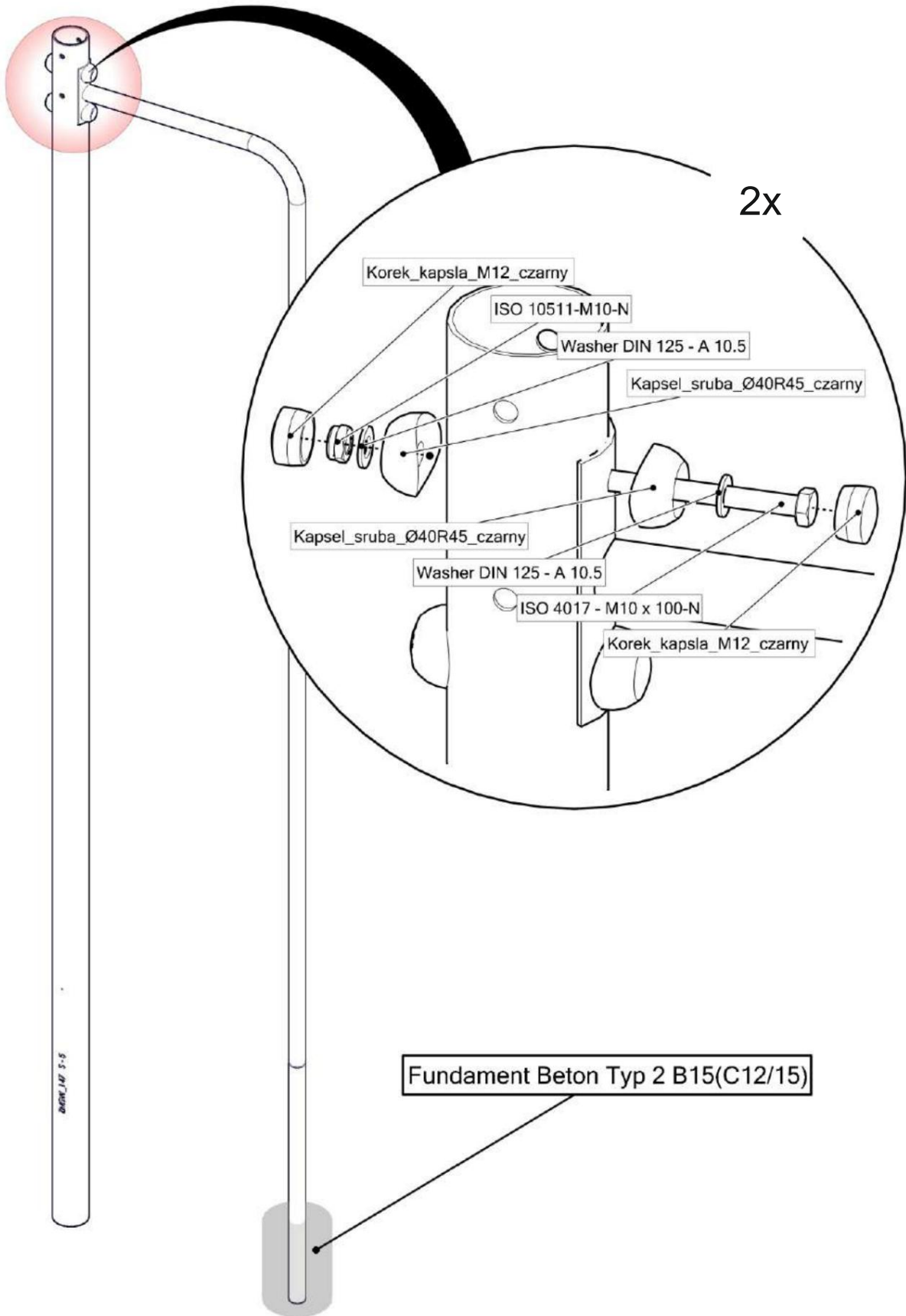

ALL STAGES OF FOUNDATION AND ASSEMBLY MUST BE PHOTOGRAPHICALLY DOCUMENTED.

THE LACK OF PHOTOGRAPHIC DOCUMENTATION WILL AFFECT THE ISSUANCE OF THE WARRANTY CARD.



INSTALLING THE CLIMBING ROPE

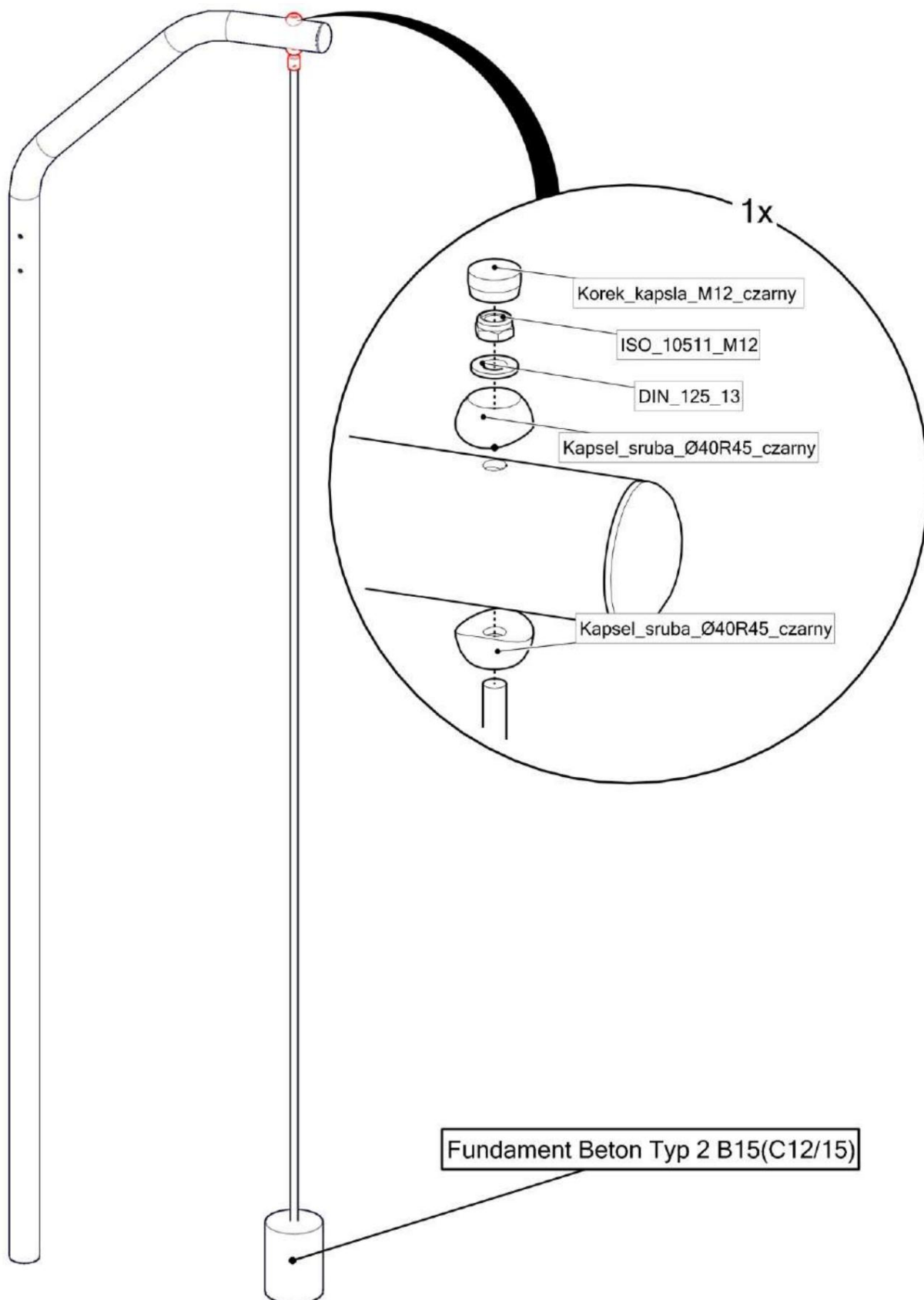

ALL STAGES OF FOUNDATION AND ASSEMBLY MUST BE PHOTOGRAPHICALLY DOCUMENTED.
THE LACK OF PHOTOGRAPHIC DOCUMENTATION WILL AFFECT THE ISSUANCE OF THE WARRANTY CARD.



PUNCHING BAG ASSEMBLY

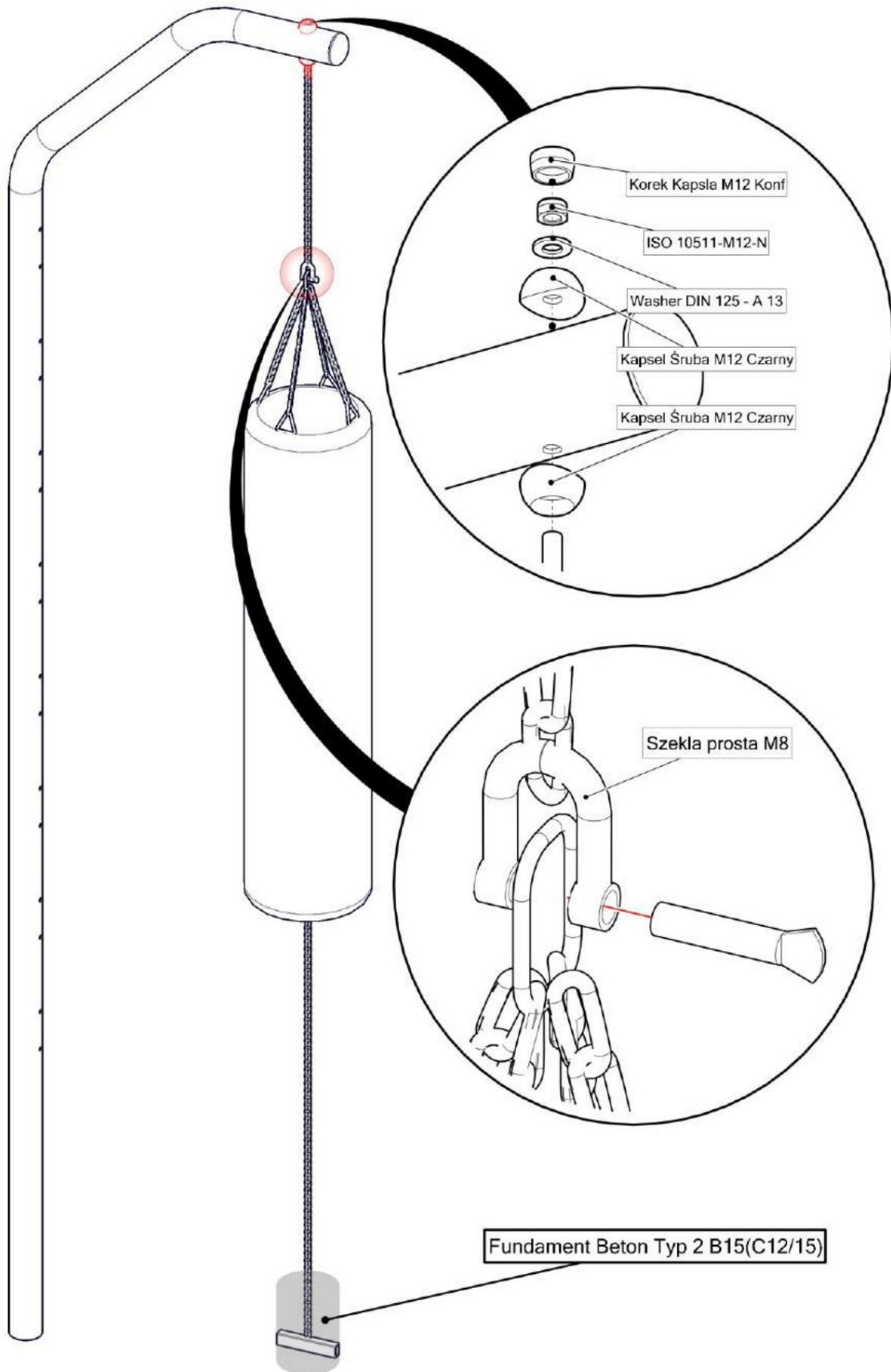

ALL STAGES OF FOUNDATION AND ASSEMBLY MUST BE PHOTOGRAPHICALLY DOCUMENTED.

THE LACK OF PHOTOGRAPHIC DOCUMENTATION WILL AFFECT THE ISSUANCE OF THE WARRANTY CARD.



SIMBA[®]
Group